



M&S Projects from Simulation Team



Liophant Simulation



M&S Net



McLeod Institute of Technology and Interoperable M&S
Genoa Center

Agostino G. Bruzzone

agostino@itim.unige.it

www.simulationteam.com

www.liophant.org

www.itim.unige.it



DIPTM
University of Genoa





Who Are We?

Universities, Research Centers and Companies operating worldwide in synergy for developing Innovative Solutions with a particular focus in Modelling and Simulation



DIME
Università
di Genova



Liophant
Simulation



Genoa



CentraLabs
Cagliari



CRiCS
Centre for Research
In Complex Systems

CSU
Australia



CIREM
Università di Cagliari



etea SICUREZZA



we speed up your business



MSC-LES



Mik
Riga TU



Universidad
de la Rioja



SimCenter Universitat
Autònoma de Barcelona



Blizzard Srl



DIPMEC
Università Calabria



Università di Perugia



LSIS
Marseille



GRV LANCE
COPPE.UFRJ.BR

Rio de Janeiro
Brazil



IMS-LAPS
Univ. Bordeaux



SPIRAS Russian
Academy of Science

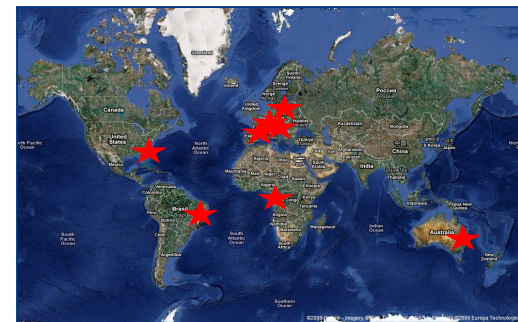

DIPTM
Università di Genova



McLeod Institute of
Technology & Interoperable
Modeling Simulation Genoa

Unclassified

Copyright © 2004-2014 Agostino G. Bruzzone Simulation Team MITIM Genoa



McLeod Institute of Technology and M&S M&S Net Genoa Center

Simulation Team
Genoa Center

Email: agostino@itim.unige.it

URL: www.mcleodinstitute.org
www.m-s-net.org

M&SNet

The research group of DIME of *Genoa University* is active from '60 in Simulation applied to Industrial Engineering and is cooperating with M&S Net and MITIM

The activities involve modeling, simulation, VV&A and analysis of Industrial Applications and Services (design, re-engineering, management, training etc.)

as:

Chemical Facilities	Power Plants	PM
Harbor Terminals	Public Services Environment	
Manufacturing	Assembling	Logistics
Public Transportation		

The Department staff is in touch world-wide with the simulation community and is present actively to conferences, exhibitions and working meetings with the major Associations, Agencies and Companies.

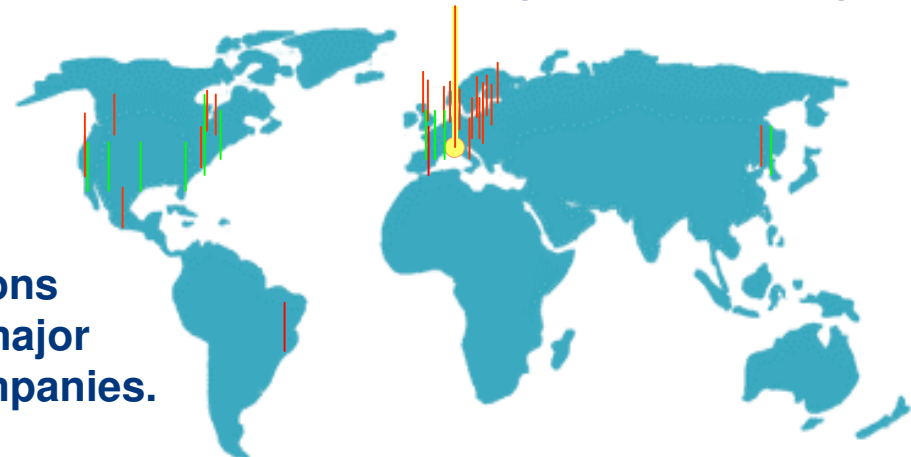

34 M&S Net Centers World-Wide





Simulation Team MITIM DIME

The Simulation Team - MITIM DIME of *Genoa University* carries out many industrial projects in cooperation with the large corporations and Small and Medium sized Enterprises; some example of recent industrial simulation project are following:1

ENI Fleet Management Planning & Scheduling

Group Chemical Plant Logistics Optimization

Ansaldo Plant Service Management and Optimization

LAMCE Oil Platform Simulation and Augmented Reality

EDA Decision Support for Country Reconstruction Activity Planning

Ford Motor New Production Line Design Based on Simulation



SOLVAY



Members of MISS are appointed in several positions in simulation community such as:

- General Director M&S Net (34 M&S Centers Worldwide)
- President Simulation Team (20 Centers Worldwide)
- Associate Vice President of SCS and Chairman of Technical Chapter
- Member of NATO SAS, MSG, and NIAG, Project Leader for Marine M&S





DIME - University of Genoa

DIPTM was founded in 1997 as evolution of the Institute of Technology and Industrial Management (ITIM) that was operative from '60. In 2011 DIPTM evolved in DIME and it is currently composed by about 80 faculty members, 15 technicians and administrative, plus several PhD Students, external Researchers and Consultants. DIME teachers are involved in Undergraduate, Postgraduate and Professional activities in Engineering, Management.

DIME active in R&D Projects for major Institutions, Companies and Governmental Organisations. DIME co-operates actively with major Excellence Centers World-Wide.





University of Genoa: an Overview

The University of Genoa is one of the oldest in Italy and in the World (founded in 1471 AD), it is located in middle of Italian Riviera.

The students are about 40,000 (about 8,000 new entries), and the engineering departments has about 7,500 students (12% in Savona Branch Departments); in effect the Savona Campus Savona holds about 1,000 Engineering Students.

That campus is located about 2 km from Savona Downtown, in an old complex of barracks recently converted into new University Buildings (over an area of 200,000 m²).

For further Information about
the University of Genoa:

<http://st.itim.unige.it>

<http://www.unige.it>



Savona Campus & Facilities



The University of Genoa includes a new campus in Savona about 2 km outside Downtown; bus services and large parking areas guarantee easy access.

That structure has been obtained transforming Army barracks; today the campus includes a big park with facilities such as tennis courts and sport grounds.

The campus holds Depts on Engineering, Economy and Education; new laboratories have been realised by Simulation Team (Cybersar Mobile Lab, HLA Lab).

Facilities for Professional Congress Centres are available in the surroundings



Savona Campus



Simulation Team Labs



Congress Centre



Partners & Spin-Off

Former Students and Researchers from MISS DIPTM Simulation Team created over the years start up companies that currently cooperate in M&S (i.e. MAST srl, Cal-Tek srl, Virtuality, DLM, AntOptima, Etea, etc); these companies are devoted to drive Innovation to Success in a wide spectrum of Application for different Business Sectors, Companies, Corporations, Agencies, Societies and Governmental Services and to put *Modeling and Simulation* to work by creating Outstanding Solutions Essential to a Better, Safer, Healthier and Wealthier Life operating worldwide.

These Partners offer a wide range of innovative products and services for M&S markets including:

- Aerospace
- Defense
- Electronics
- Engineering
- Safety and Security
- Retail
- Environment
- Logistics
- Service to the Society (nutrition, health care)
- Petrochemical
- Energy and Power
- Shipping & Transportation





Liophant Simulation

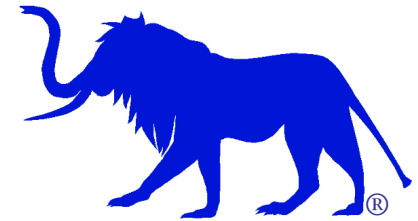

Email info@liophant.org

The *Liophant Simulation* involves World-Wide over 120 Scientists and Technicians working in Companies and Academia. The *Liophant* develops Advanced R&D Projects for Real Applications:

The *Liophant Simulation* promotes international Cooperations and exchanges with Excellence Centers World-Wide (i.e. NCS, KSC, VMASC, KPI)

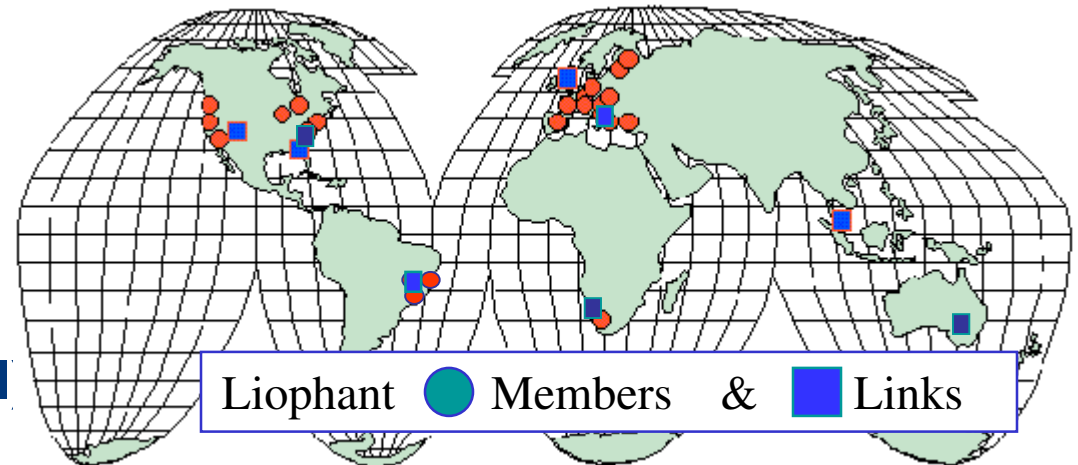

www.liophant.org



The International Activity of Liophant Simulation



Exchange Activity 2012
PhD, Master, BS





The International Activity of Liophant Simulation





Simulation Technology Transfer

Since 2000 Simulation Team - DIPTeM support Professional and Academic MITIM International M&S Certification Program:

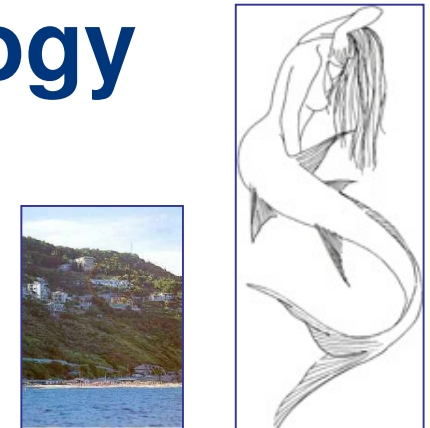
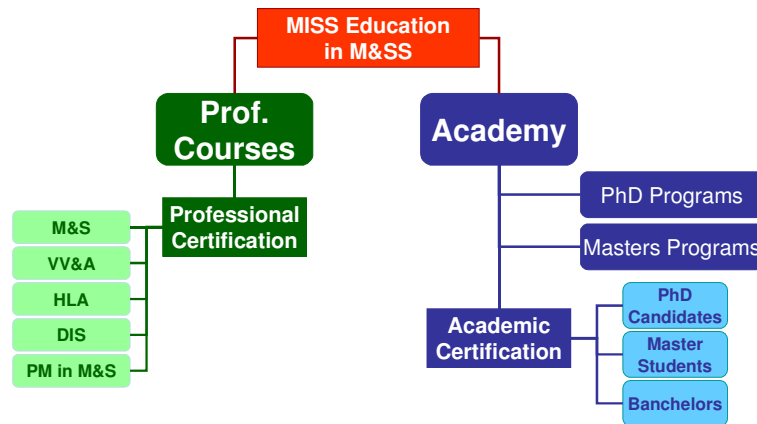

Course Location



Lecturing



Team Working & Exercises

The Lecturers included experts from major excellence centres (i.e. Boston College, Genoa University, NASA, DMSO, National Center for Simulation, SAIC, Aegis, CSY., Riga TU, UCF , McLeod Institute of Technology and Inter.M&S). The Professional course attendance (PM >100, M&S 60, HLA 40, VV&A 20) included Companies (i.e. Piaggio Aero Industries, Alenia Aeronautica, Alenia Marconi, SIA, Fincantieri, COOP), Academia (Pol.Torino, TU Delft, Univ.Marseille, Pol.Milano, Univ.Firenze, Univ.Bari, Univ.L'Aquila, etc.) and National and International Services (i.e. Army, Navy, Air Force, Joint Forces)



SIREN Professional Courses

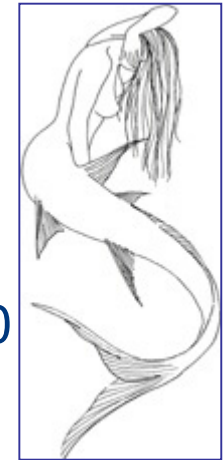

The professional courses have been organized since 2000 for World-Wide professional experts and technicians, in English, Italian and French, including:

- PM: Project Management for M&S
- M&S: Modeling & Simulation
- Interoperability M&S
- HLA: High Level Architecture
- VV&A: Verification, Validation & Accreditation
- RCM: Reliability Centered Maintenance



The courses include lecturing and exercises; teachers are usually world wide experts from major excellence centers (i.e. Boston College, MITIM Genoa University, NASA, DMSO, National Center for Simulation, SAIC, Aegis Technologies, CSU, Riga TU, UCF, M&S Net, etc.).



Simulation Team



SIMCJOH

Simulation of Multi Coalition Joint Operations involving Human Modeling

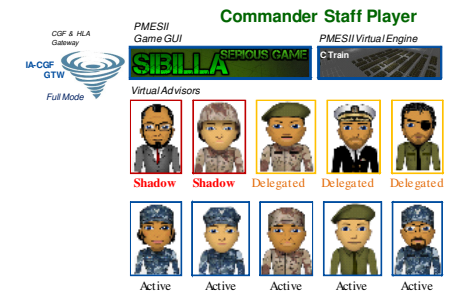

The SIMCJOH (Simulation of Multi Coalition Joint Operations Involving Human Modelling) programme is a new research initiative lead by Genoa University. SIMCJOH objective is to create a framework to immerse the Commanders and their staff in critical decision making over Joint and Multi-Coalitions scenarios, considering a strong involvement of human factors with a particular focus on issues of refugees and civilians, natural disaster relief with presence of civilians in a theater of military operations; the initiative get benefits from innovative Simulation Team researches in population and human behavior modeling

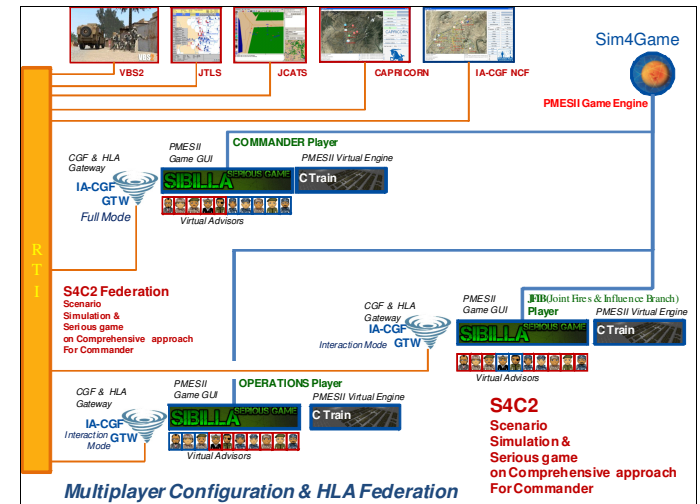
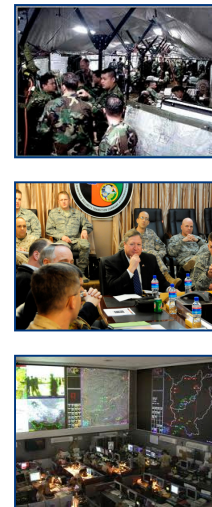



SIBILLA

*Simulation of an Intelligence Board
for Interactive Learning and Lofty Achievements*



- SIBILLA is multiplayer web strategy game that simulate Terrorist Actions organized by different organization directed by IA that plan, prepare and execute attacks on specific:

- Location
- Site
- Time
- Threat Type

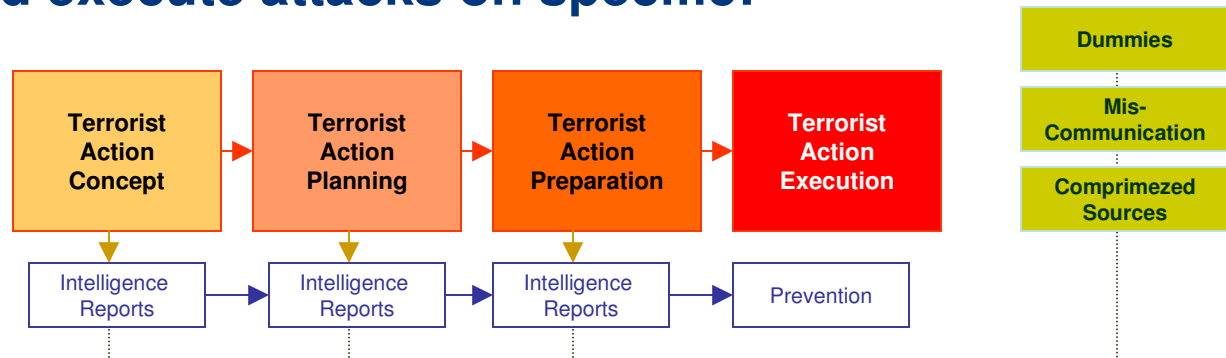

- The intelligence reports are distributed among the players based on their capabilities and shared by a stochastic engine
- The Identification of the attacks in time is the key for individual success; the players cooperate and compete for budget and success
- Threat missed to be identified generate terrorist attacks that reduce global trust and support to intelligence agencies

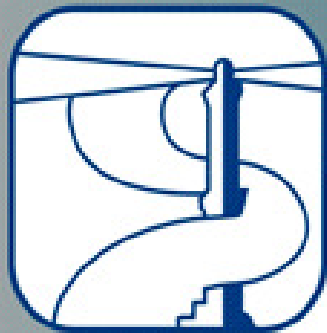

DYTACCO

Dynamic Targeting Collateral Damages and Consequences



Simulation Team



DYTACCO is a Dynamic Targeting simulator focused on evaluating collateral damages, risks and consequences of operations in complex operative contexts. DYTACCO is a Serious Game conceived for commanders and intelligence staff training. The Simulator proposes challenging Dynamic Targeting Cases to the JFIB (Joint Fire and Intelligence Branch), requiring them to define the Decision Making Briefing for Commander considering risks, collateral damages, consequences, available assets, caveats, etc.

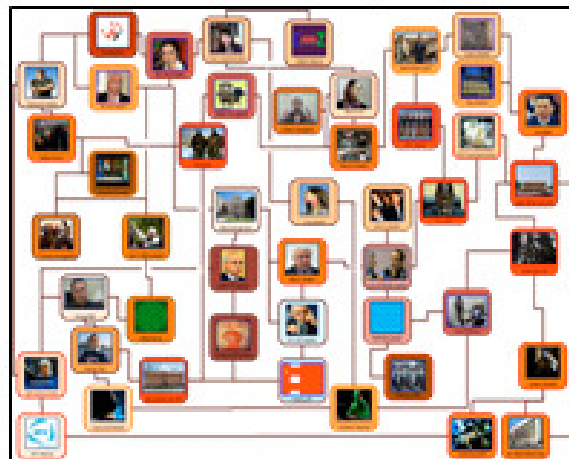

The Commander finalizes the decision on the Dynamic Target case that is elaborated by this simulator providing direct and indirect outcomes of different alternatives on the scenario evolution.

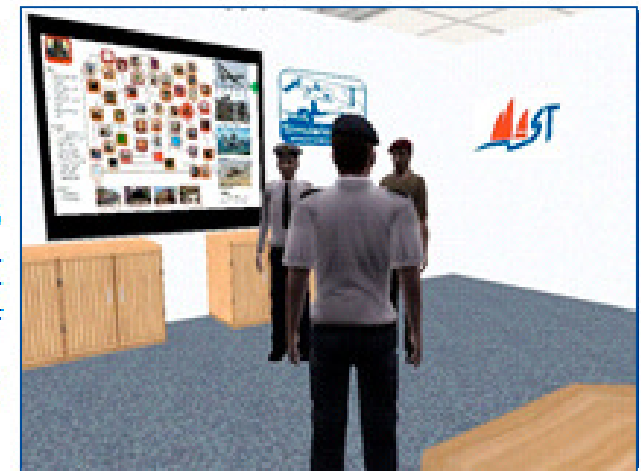



SGT-SDM

Serious Games for Training in Strategic Decision Making



ACT has activated the SGTSDM as a R&D Project to investigate the use of Serious Games for Training in Strategic Decision Making. The project involves an international team including ACT, NATO Defense College, ARRC, M&S COE, Simulation Team, MITIM DIPTM University of Genoa and MAST.





CAPRICORN

Civil Military Co-operation And Planning Research in Complex Operational Realistic Network

- CAPRICORN is an active EDA R&D Project devoted to develop capabilities in the complex and critical sector of Military Operation Planning, specifically for asymmetric warfare scenarios involving CIMIC and PSYOPS, by using CGF (Computer Generated Forces) based on Intelligent Agents (IAs)

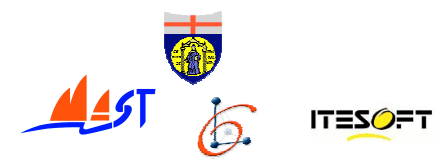
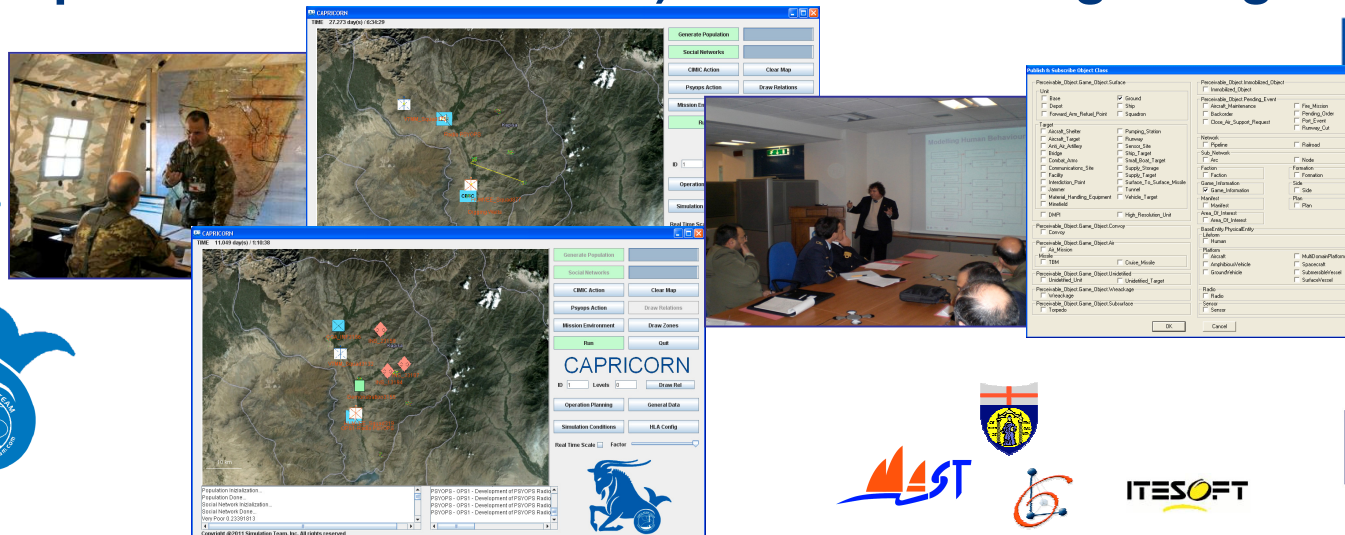



Haiti Case

IA-CGF NCF Riots & IA-CGF NCF EQ

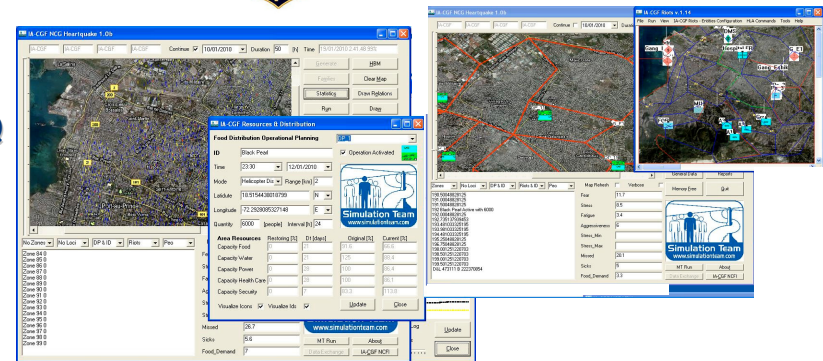

The Demonstration was based Haiti Earthquake 2010 and presented by USJFCOM at ITEC within 2 months.

The demonstration was devoted to show the potential of interoperability in combining different simulators for full coverage of a complex problem such as that one of Haiti.

Simulation Team was involved by using his interoperable IA-CGF reproducing Population Behavior, Human Factors (famine, stress, diseases, fear, aggressiveness), Riots and Gang Activities as well as the impact of the Simulation Earthquake





PSYSOP

Psychological and cultural Simulation Of Population



PSYSOP is a Simulator Reproducing a Town including Psychological and Cultural aspects affecting the Population behavior and reactions. The model includes social, cultural, educational, psychological, gender, age, religion and many other parameters including the social networks related to family and work environment and their influence on the scenario evolution.

PSYSOP 1.0 Statistics:

- Inhabitants: 20000
- Manned: 5567
- Sons: 4323
- Olds: 2458
- Friends: 18962
- Education: 1.40625
- Sex: 0.474500000476837
- Age: 38.9463396987207
- Social: 1.81474995613058
- Party: 2.31309930310669
- Religion: 4.24845020675559



RATS

Riots, Agitators & Terrorists by Simulation



RATS is a demonstrator based on Intelligent Agents for simulating Riots, Civil Disorders as well as Agitators and Terrorists actions within Urban Scenarios considering different entities and influence of Human Factors such as :

- Paramilitary Forces
- Police Forces
- Military Units
- Population

- Terrorists
- Firefighters
- NGOs
- Protesters

- Warlords
- Health Care
- Governmental Entities
- Ethnic Groups



	CELEBRATION	GRASS	LANCERS	SECULAR	SECULAR	SECULAR	SECULAR
	POPULATION	MINORITY	MINORITY	POPULATION	POPULATION	POPULATION	POPULATION
CELEBRATION POPULATION	Neutral	Neutral	Foed	Neutral	Foe	Foed	Foed
GRASS MINORITY	Neutral	Neutral	Neutral	Foe	Neutral	Neutral	Neutral
SAXONS MINORITY	Neutral	Neutral	Neutral	Foe	Neutral	Neutral	Neutral
STREET'S LOCAL POLICE	Foed	Neutral	Neutral	Neutral	Foe	Neutral	Neutral
BOYTERENA FEDERAL POLICE	Foe	Foe	Foe	Neutral	Foe	Foe	Foe
SAXONS LIBERATION FRONT	Foe	Neutral	Neutral	Foe	Foe	Foed	Foed
CELEBRATION LIBERATION MOVEMENT	Foed	Neutral	Neutral	Foe	Foed	Foed	Foed
GANGS	Foe	Foe	Foe	Foe	Foe	Foe	Foe
BLUE FORCES	Foe	Foe	Foe	Neutral	Neutral	Foe	Foe
RED FORCES	Foe	Foed	Neutral	Foe	Foe	Foed	Foe

Simulation Team



SLAMS

Simulation Lean Advanced Mobile Solutions



Microsoft



New technologies make possible to develop simulation solutions tailored for smartphones and tablets; SLAMS (Lean Simulation Advanced Mobile Solutions) is research coordinated by University of Genoa with the aim to identify solutions for education and training for defense, this goal will be reached through models and simulators which are expected to take advantage from these hardware solutions.

In particular, Serious Games based simulators for training will be developed, in terms of approach and engines for games as well.





CRYSTAL

Cyber Reality Simulation for Threat Assessment and Defense Learning



Simulation Team



The CRYSTAL is a research coordinated by Genoa University. CRYSTAL Goals is to develop a simulation framework able to simulate Cyber Defense scenarios related to the Different Layers representing Strategic National Assets (i.e. energy, communication, finance, transportation); CRYSTAL is a modern interoperable architecture allowing a modular approach aimed at advancing the research in a Cyber Defense by using a federation of interoperable stochastic simulators driven by IA-CGF (Intelligent Agents Computer Generated Forces).

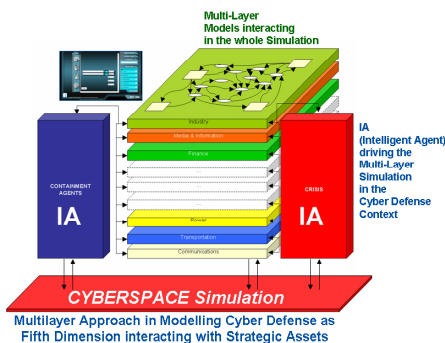



IA-CGF UCOIN

Intelligence Agent Computer Generated Forces UAV and Counter-Insurgency

IA-CGF UCOIN is a Stochastic Simulator of Joint Operations involving UAV (i.e. Rapiers and Predators) for Counter Insurgency in coordination with other assets (i.e. ground units, attack helicopters, planes).

IA-CGF UCOIN allows to simulate complex scenarios where population and civilians are used to hide and shield insurgent activities and to estimate operative performance as well as collateral damages and costs. IA-CGF UCOIN is a support to evaluate technological improvements as well as new operative policies, procedures and to experiment doctrine and enemy tactics evolution.

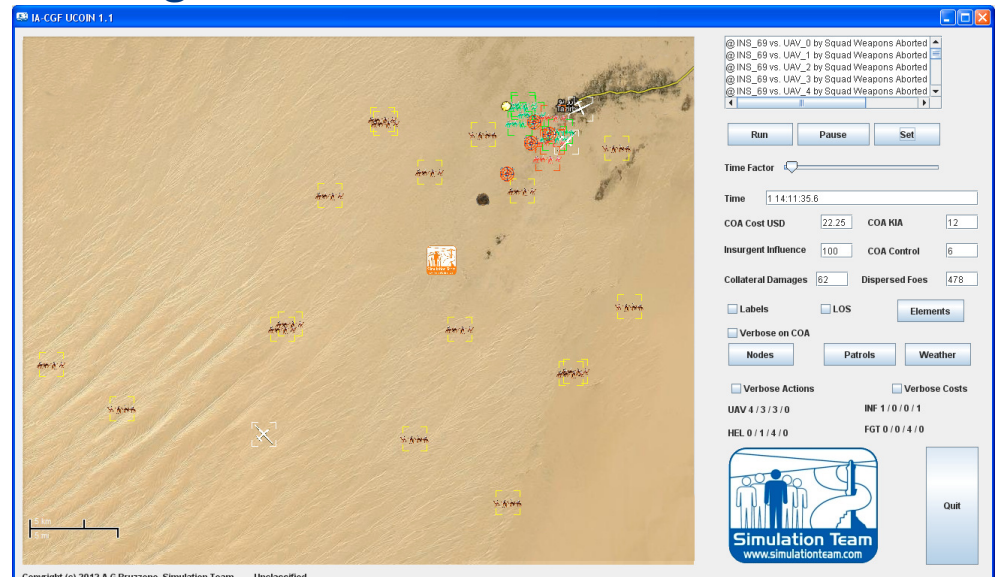



ST_VIV

Simulation Team Virtual Intelligent UAV & AUV



ST_VAV is a Real-Time Agent Driven Simulation of Autonomous Vehicles that operates as swarms and to test Virtual Manned Drone Concept within an HLA Federation (ST_VP Federation). This Synthetic Environment supports different types of UAV (i.e. Predator, Reaper and UACV) and AUV (autonomous underwater vehicle) such as sea gliders. Currently ST_VAV allows to manage different swarms of UAV (i.e. 12 Unmanned Aerial Vehicles) flying as a wing controlled by a Intelligent Agents or directed by an Operator immersed in the Simulation Team CAVE (Covering 270° Horizontal and 120° Vertical, 6 DOF and/or 3 DOF Motion Platform, 3D Stereo Surroundings) integrated with Biometric Devices (i.e. eye flickering, eye tracking, cardio frequency, muscular tone).

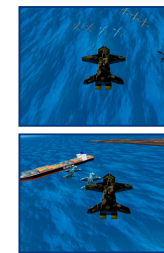
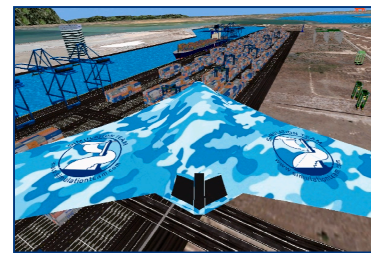

www.liotech.co.uk



DIPTM
Università di Genova



IA-CGF MODULES

The new *IA-CGF* Modules devoted to create the simulation of complex Scenarios include:

- *IA-CGF Units*
- *IA-CGF Human Behaviors*
- *IA-CGF Non-Conventional Frameworks*





IA-CGF Units

IA-CGF Units are a set of interoperable units with capability to be integrated in constructive simulation

- Police
- Gangs
- Local Population
- Rioters
- Insurgents
- Terrorist
- Local Authorities
- Warlord
- Criminal Organizations
- NGOs (CIMIC ops.)
- Civil Personnel (CIMIC ops.)
- Domestic/National Situation (for instance for troops moral):
 - Population
 - Media
 - Lobbies
- International Public Opinion
- International Diplomacy
- New Threats (i.e. 2nd Generation Terrorists)



These are examples of non-conventional units controlled by IA-CGF





IA-CGF Human Behaviors

Specific modules with *IA-CGF Human Behaviors*:

- Fear
- Stress
- Fatigue
- Training Level
- Aggressiveness
- Ethnic Factors
- Religious Factors
- Combat Skills/Experience



IA-CGF Human Behaviors operate as a set of further characteristics to be added to each unit in constructive simulation.

i.e. now in constructive simulation every unit in the scenario have infos about status and type of ammo, by IA-CGF it will be added dynamic information about level of fear and stress and the Units performing according to it



IA-CGF Non-Conventional Frameworks



It is important to consider the integration in a scenario of the *IA-CGF-Non-Conventional Frameworks (IA-CGF-NCF)*, each simulating specific events:

- *IA-CGF CIMIC/HUMANITARIAN FRAMEWORKS*

- Food Distribution
- Reconstruction



- *IA-CGF Homeland Security and Civil Protection FRAMEWORKS*

- Natural Disaster (i.e. Hurricanes, Earthquakes)
- Man Made Disasters (i.e. Explosion, Hazardous Material Spills)
- Evacuation



- *IA-CGF PSYOPS and INTELLIGENCE FRAMEWORKS*

- Integration *Sibilla*® Serious Game for Intelligence Officers training

In non conventional scenarios for particular training purposes.

We can imagine to have active different non conventional Frameworks, in different locations, with different level of detail inside the simulated theater.





CGF C4 IT

Computer Generated Forces C4 for Italian Army



CeSiVa

Simulation Team



CGF C4 IT Project allows to measure the effectiveness of different C2 Maturity Models involving local and coalition forces, police and other resources in an foreign urban framework. This Federation is based on use of IA-CGF and SC and is devoted to support Italian Army Simulation in term of experimentation and analysis of technologies and policies

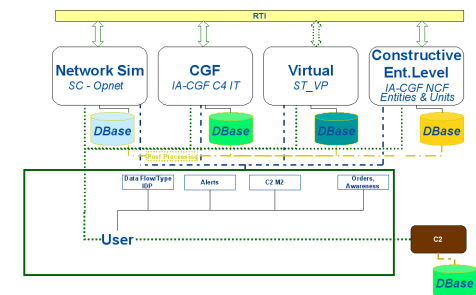
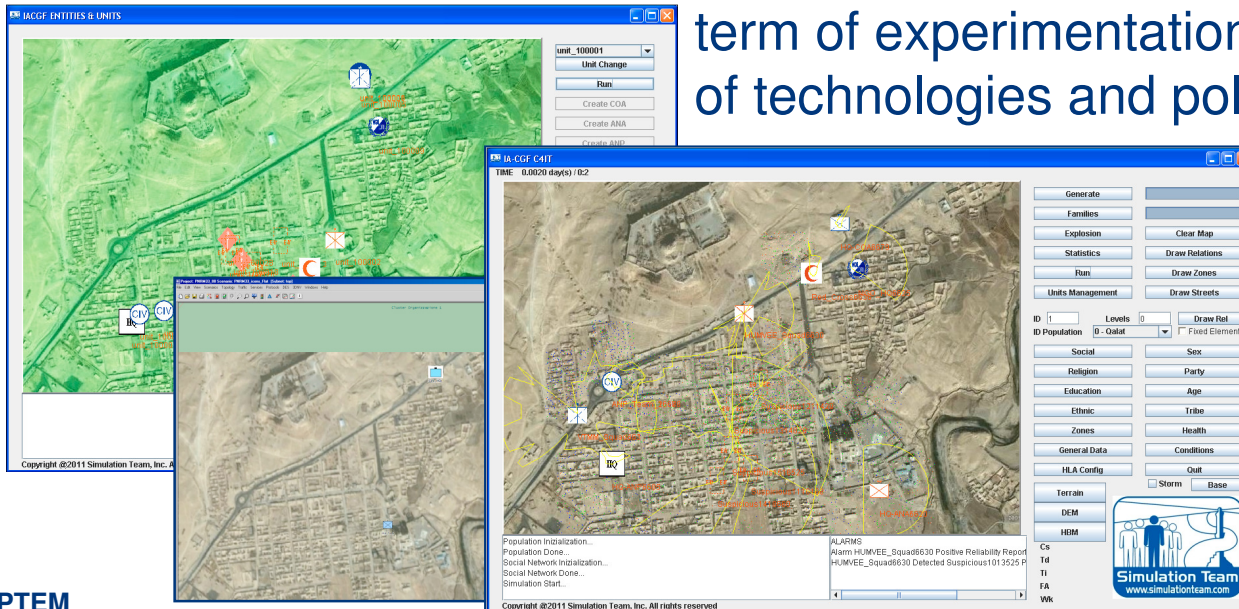



MIAC

Models of Intelligent Agents for Computer Generated Forces



Simulation Team



MIAC NCF and MIAC Configurator are designed to drive a Federation where the IA-CGF allows to reproduce population within an Afghan Village. MIAC Federation is designed to operate under HLA using RTI MÄK on Workstations using Windows XP™ O.S. and installing IA-CGF NCF MIAC© derived by IA-CGF NCF PSYSOP© MIAC is interoperable with other federates (i.e. Scenario Generators) while the MIAC Configurator supports the Scenario Definition

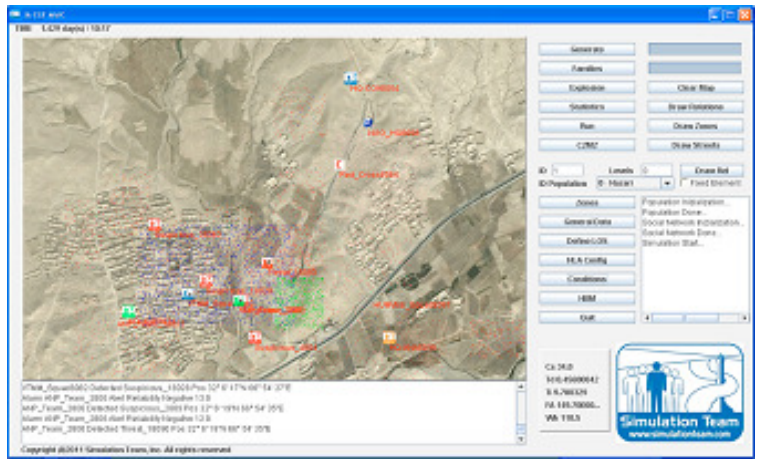
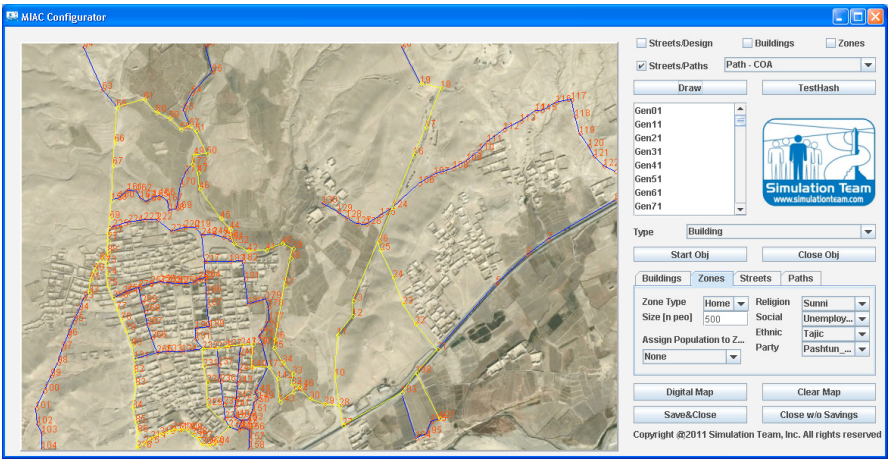
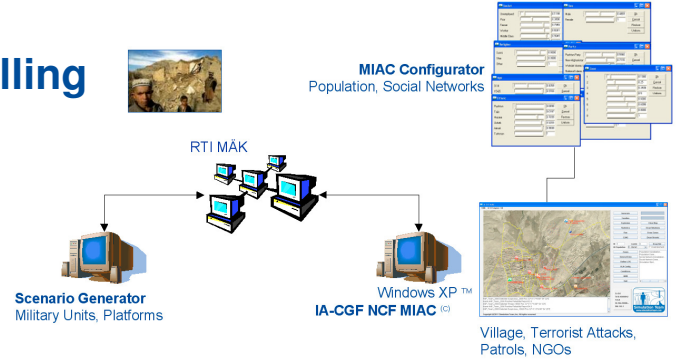



PIOVRA

Polyfunctional Intelligent Operational Virtual Reality Agents

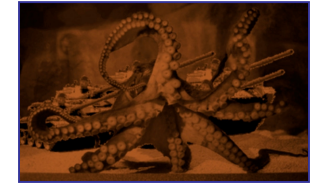

PIOVRA was an EDA Project developed in cooperation with Italian and French MoDs in partnership between MITIM DIPTM & LSIS.

PIOVRA allowed to develop a new Generation of CGF able to simulate “Intelligent” behaviors, filling up the gap between user requirements and current available CGF performances

PIOVRA demonstrated the new intelligent agents directing the CGF as effective models integrated in HLA Simulation reproducing Urban Disorders integrated in a Theater Simulation

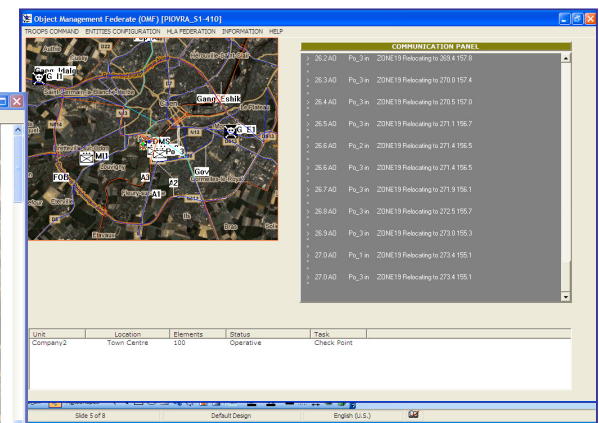
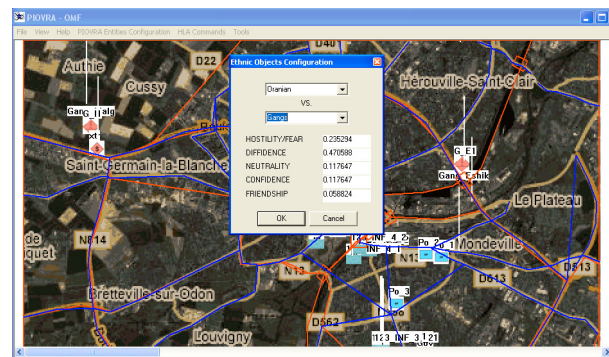
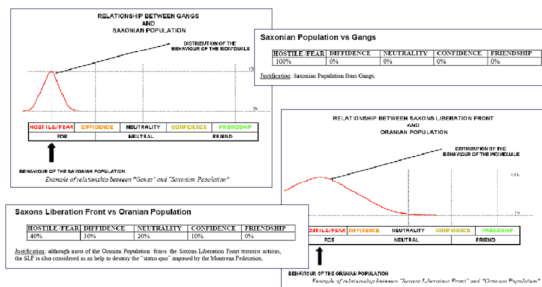



MOSCA

MOdelling Supply Chain Attacks



MOSCA project is devoted to the development of Models for estimating the impact of attacks or disasters affecting supply chain of consumer goods; MOSCA includes dynamic impact of events on consumer emotions as well as effectiveness of countermeasures

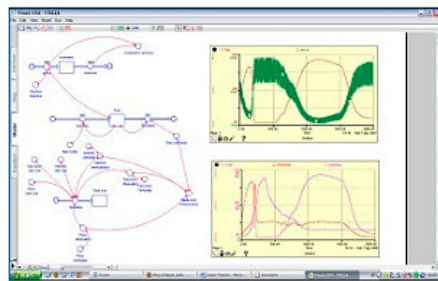
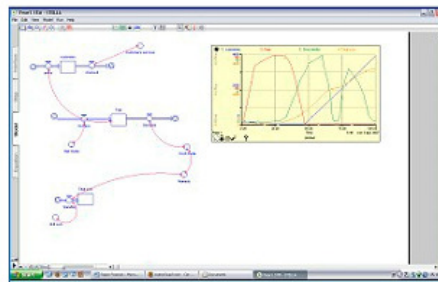

Simulator of Attacks to Retail Chains.txt - Blocco note

File Modifica Formato Visualizza ?

Event: Contaminated fresh food Bad media: Moderate Aggression

Fear perception: 11

Store Code: 62 Division code: 6

Media Spending: Internet 34, Television 33, Press 25

Delay	Internet: 20	Television: 10	Press: 30
Duration	Internet: 60	Television: 60	Press: 30
Media Unit Cost	Internet: 1	Television: 2	Press: 3

Average Arrives rate: 47 Average Checkout rate: 47

"Terrorism Attack In Retail Buisness" Simulator

GO! Load

Simulatore / Codici / Historical / Matrix / Fear / Arriving / Badmedia / Mediums / Spending / Timecardown / Old-Data / data /



ASPID

Advanced Supply chain Protection & Integrated Decision support System



This research is focused on the development of innovative tools for analyzing and optimizing the risk related to the evolution of the elements in the supply chain. ASPID proposes an innovative use of modeling for evaluating the impact on the supply chain of different aspects such as international competition, know-how diffusion in new areas, critical events and disasters





RAILSEC

Railways Security

The project concentrated in developing models for Risk Analysis related to Security in Rail Environments. The project develop emergency management and event simulators as well as model devoted to identify medium and long term effects in term of costs, resources and impact on the overall environment.

The project was developed in cooperation with Institutes in North America and focused on terrorist attack issues

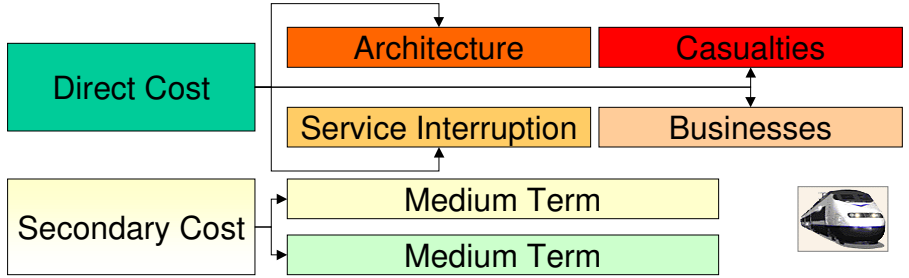
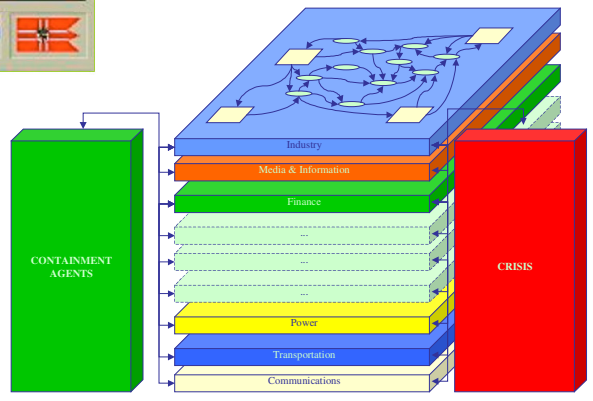
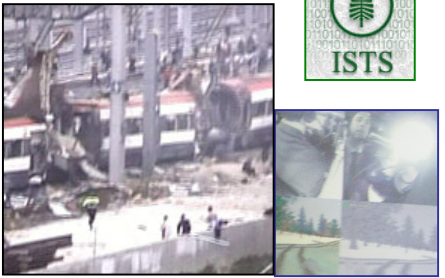

Simulation Team
Genoa Center



SESISEP

Security Simulation of Sea Port

The project concentrated in developing simulation models to support Security in Ports in term of Risk Assessment, Training, Security Solution Analysis, etc. The initiative is modeling ports, terminals, operative procedures, regulations & policies.

The model was successfully applied to evaluate the impact of ISPS, MTSA and SCI evolution in large container terminals. A demonstrator is available on:

www.liophant.org/projects/secsim



(SEAPORT Simulator)

GRAPHIC USER INTERFACE

Ship Characteristics

- Min. Container Number to unload: 0
- Max. Container Number to unload: 1500
- Mean Interarrival Time (h): 12

Technical Equipment

- Tugboats Number: 4
- Mean Tugboat speed (m/s): 1.667
- Min. Unloading Time per container: 0.5
- Max. Unloading Time per container: 1.5
- Forklifts Number per Berth: 12
- Mean Forklift speed: 13.2

External Truck Characteristics

- Trucks Number: 35
- Mean Truck speed: 18



INDASTRIA

This model is inspired by real case and simulate a region subjected to social, economic crisis, it includes:

- Small Region Simulation
- Social Multi Ethnic Reality
- Real & Fake Economy
- Civil Disorders
- Federal vs. Local Authorities
- Polices vs. Crime Organizations

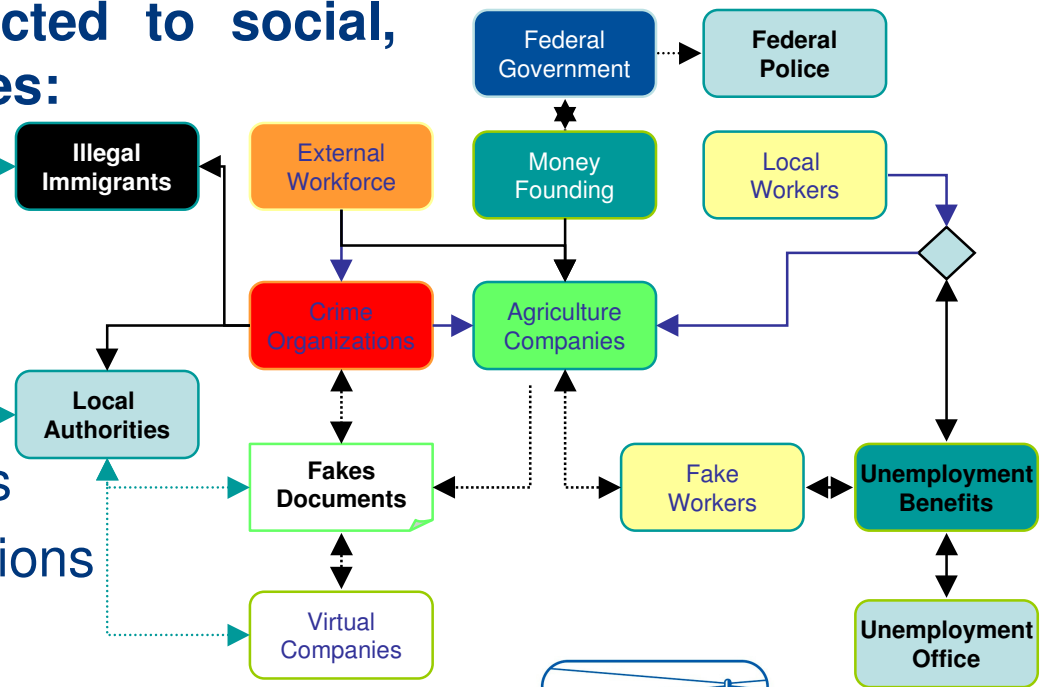



PANDORA

PANdemic Dynamic Objects Reactive Agents



CRiCS
CENTRE FOR RESEARCH
IN COMPLEX SYSTEMS

- PANDORA addresses the dynamics of the spreading of a Pandemic and experiments are on-going on H1N1 influenza A virus by a joint simulation project involving USA, European and Australian R&D Centers (MITIM DIPTM, Dartmouth College, CRiCS).
- PANDORA proposes to use an evidence-based approach whereby statistical data (census) and ethnographic surveys are source for the model and integrated with Human Factors representing the psychological and social parameters impact on people behaviors and their reaction to containment measures and policies
- PANDORA evaluates the efficacy and cost benefit of various mitigation strategies such as school closures, target anti-viral prophylaxis and other mitigation measures, level of absenteeism, and its impact on commerce, industry, economy and functioning of society as well as population attack rate, risks related to specific groups and on flows across State borders.

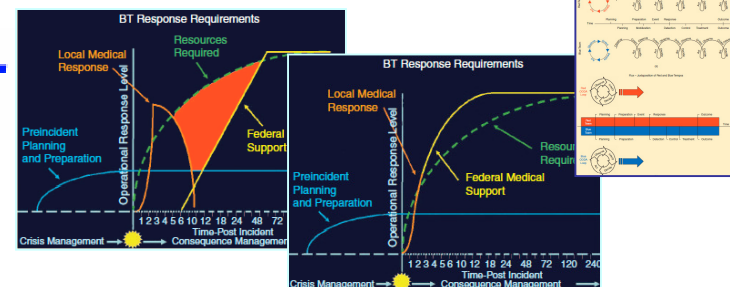
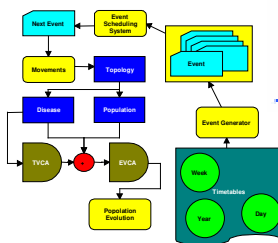
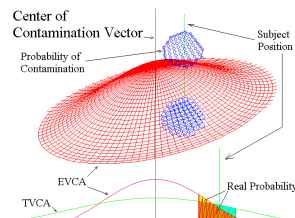



CUMANA

*Cooperative/Competitive Utility for Management
and Advanced Networking skill Acquisition*

CUMANA is a Web Multiplayer Game that provides the opportunity to play interactively a cooperative/competitive game, in a distributed environment where different “Managers” operate concurrently with benefits and penalties connected to both common and individual objective achievements related to their role in their Corporation.

The main goal is to share information in order to support Decisions Making in a Corporation Framework based on market reports affected by risks

The Identification of the market event in time is the key for individual success of each player as well as the overall corporation, while risks not properly addressed generate losses for the whole players

Simulation Team





PAS

Plant Advanced Simulation

The PAS (Plant Advanced Simulation) is an initiative for developing a real-time distributed interoperable simulation of complex industrial plants to support different aspects including design, engineering, training. The simulation environment could be used to improve safety and security as well as to support education.

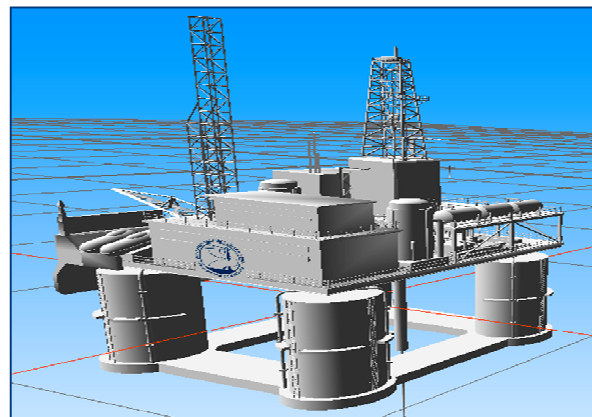
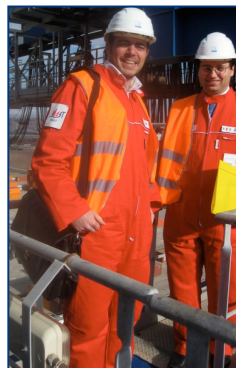
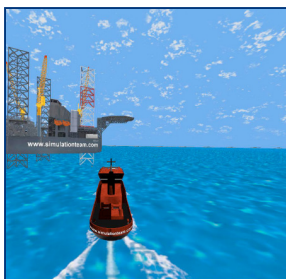
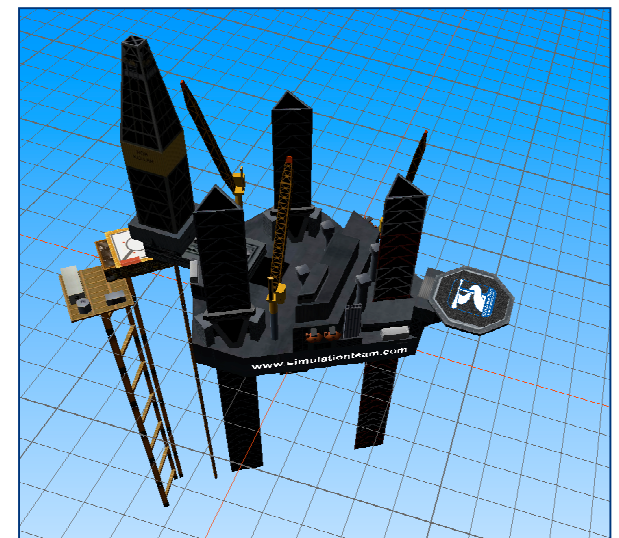
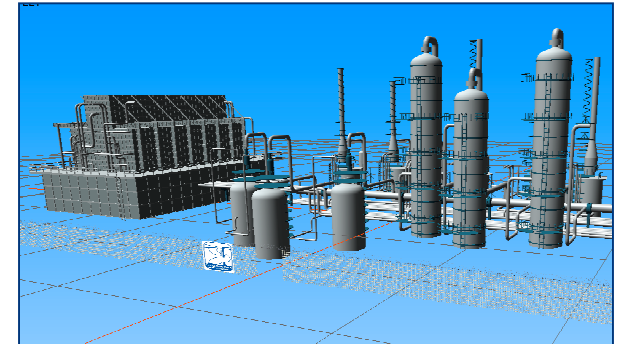
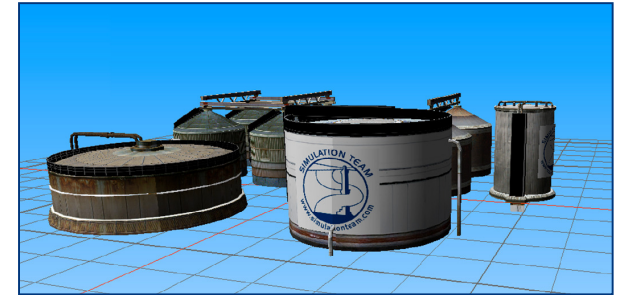



CALYPSO

Carrier Life cYcle Period Simulation & Optimization



CALYPSO project investigated methodologies and techniques devoted to analyze the Life Cycle of the New Italian Carrier Cavour. CALYPSO included development of Tools for comparing costs, operations and performances of different Carriers.

swbs	descrizione
	sistema piattaforma
	sistema combattimento
	sistema integrato di telecomunicazioni
200	impianto di propulsione
300	gruppo impianto elettrico
400	gruppo comando e sorveglianza
500	gruppo impianti ausiliari
45111	radar di scoperta navale
41211	sottosistema comando e controllo
41511	sottosistema data transfer system
45112	sottosistema radar di navigazione
42811	sottosistema di navigazione
48412	sottosistema meteo oceanografico
440	sottosistema di comunicazioni esterne
430	sottosistema di comunicazioni interne

CALYPSO - Carrier Life cYcle Period Simulation & Optimization
PLANE EVALUATION

Historical data | Plane | Coeff menu

Ref-Comparison: Nimitz-Cavour

Direct operating and support cost

Personnel coeff	N° personnel	0.313
Fuel coeff	hp	0.421
Depot maintenance	Full load displacement	0.335
Others	Acquisition cost	0.670

Indirect: Training, Fuel del, Other

Click for final estimation

Main menu | Historical data | Technical data | LCC fiscal year 97 (30 years)

2005 © Copyrights DIPTeM University of Genoa

ACASO: Advanced Carrier Acquisition cost Simulation & Optimization

Historical data | Technical data | LCC fiscal year 97 (50 years)

8.20424	8.43488
8.20424	8.43488
8.20424	8.43488
11.724	13.4826
11.724	13.4826

2005 © Copyrights DIPTeM University of Genoa



ACASO

Advanced Carrier Acquisition and Operation cost Simulation & Optimization



ACASO is a system for design new Vessel by simulating their performances in relation to their operative profiles and maintenance policies. The system estimates the unknown characteristics of the new Vessel Systems by applying advanced AI techniques (genetic algorithms) and evaluating different hypotheses and scenarios

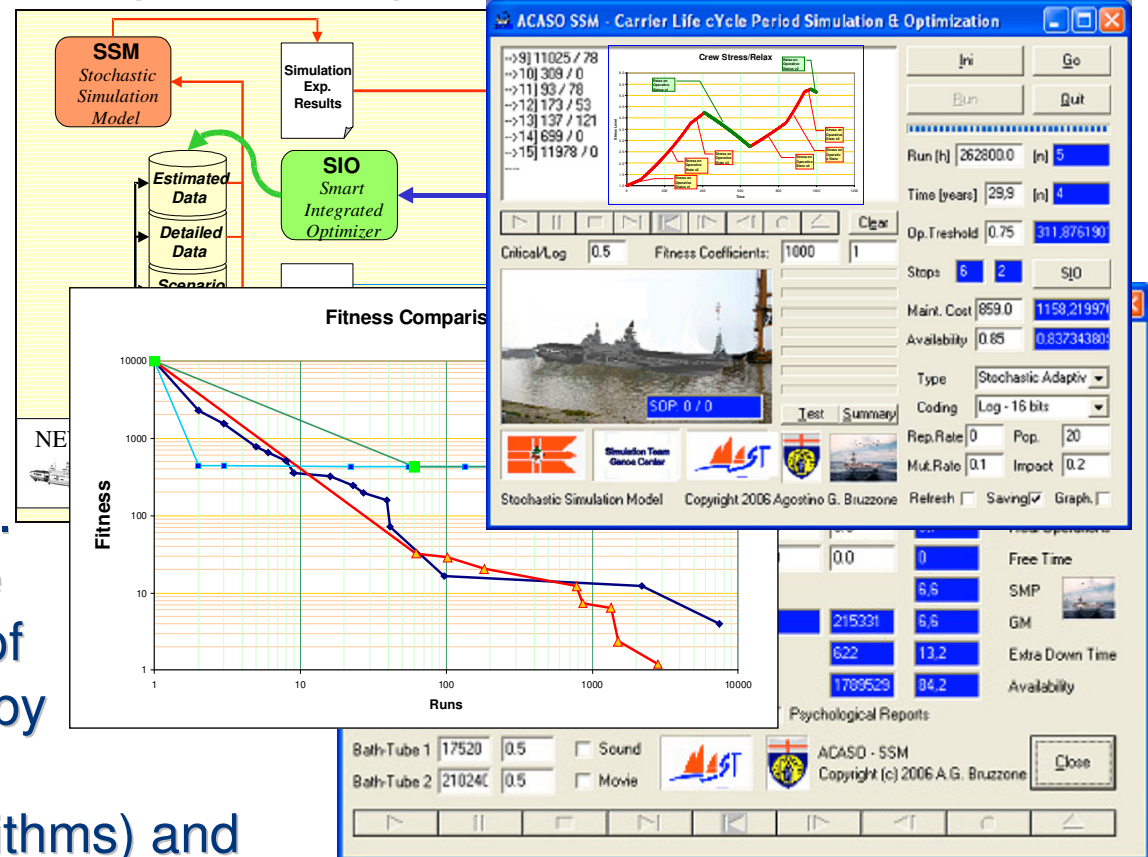



KATRINA LIKE

KATRINA LIKE was a Joint Venture that Demonstrated the possibility to Model a National Crisis and to Simulate a Wide Emergency; the Project successful demonstrated the Simulation of an Hurricane Impact on the Transportation Layers of Louisiana State Considering Traffic Cargo, Evacuation Activities, etc.

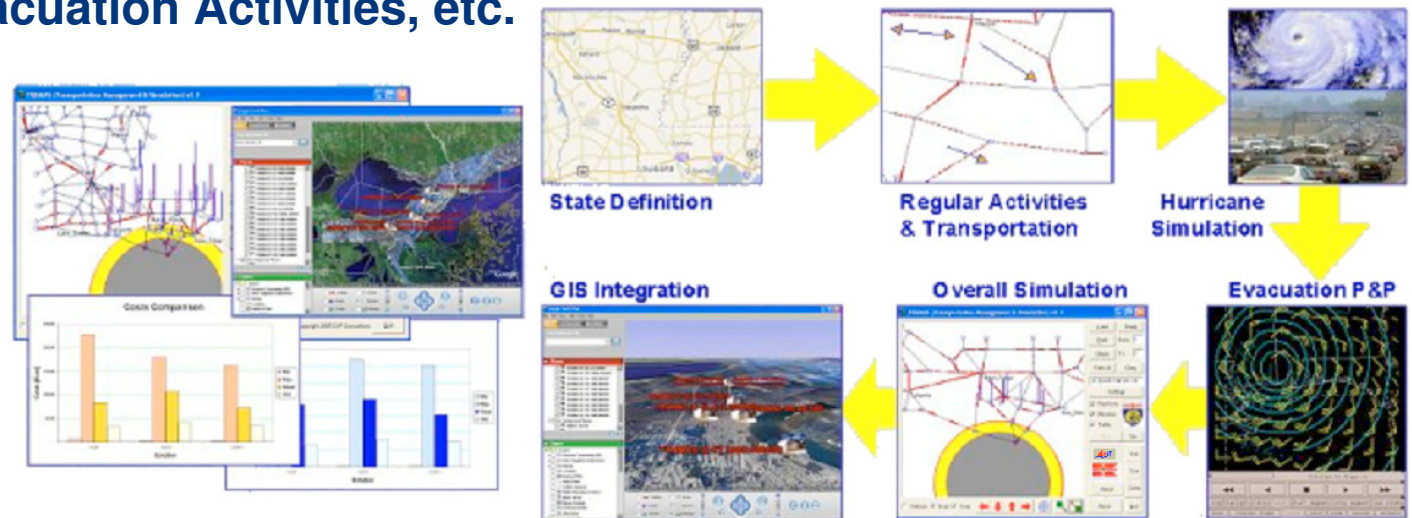



CIPROS

CIVIL Protection Simulator

CIPROS is a modular approach for Civil Protection that integrates GIS and Simulation.

CIPROS generates Crisis Dynamic Web Sites for supporting training and information share

CIPROS includes simulation of:

- Explosions
- Hazardous Material Fallout
- Flooding

CIPROS support definition and management of different Alert Level and Threats Classification as well as evacuation Procedures for Population and people with impediments

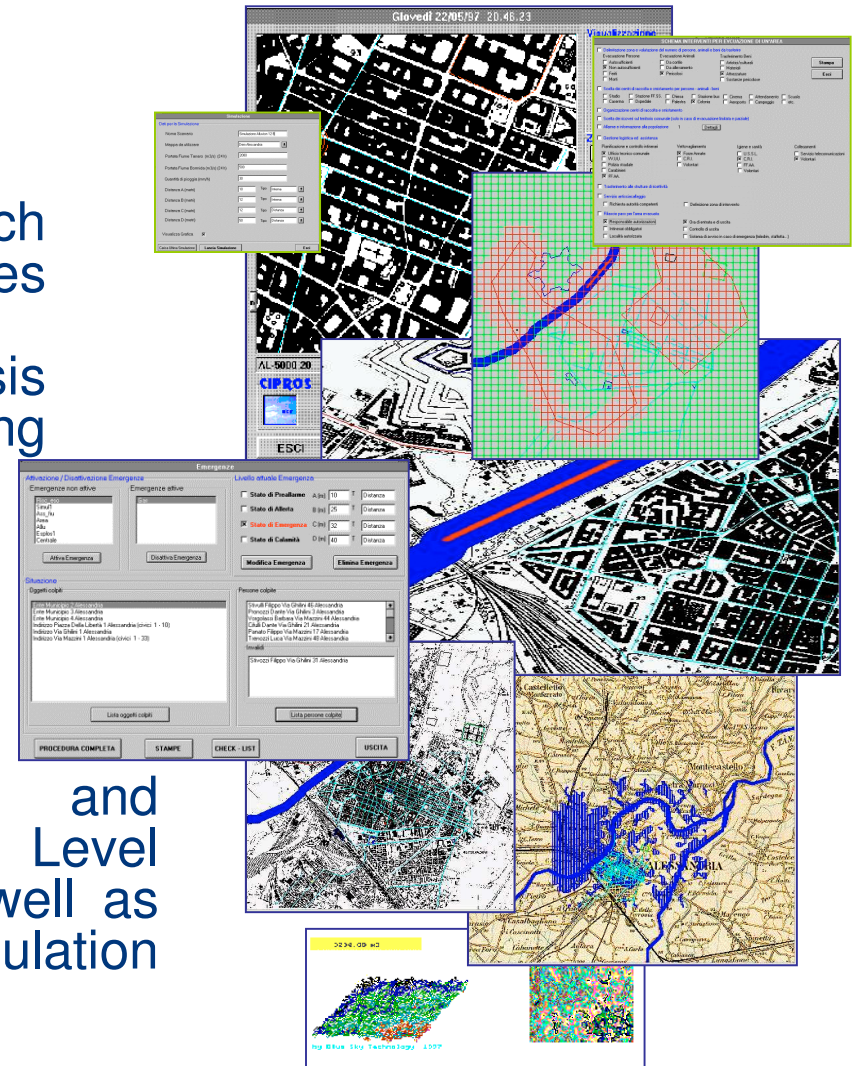



MESA

Maritime Environment for Simulation & Analysis

MESA is an integrated environment to perform simulation and risk analysis in ports and maritime sector.

MESA is devoted to support port organizations, entities and operators in Emergency & Environmental

Management.

MESA is a modular system based on combined simulators running on PC and providing direct output also on WWW servers.

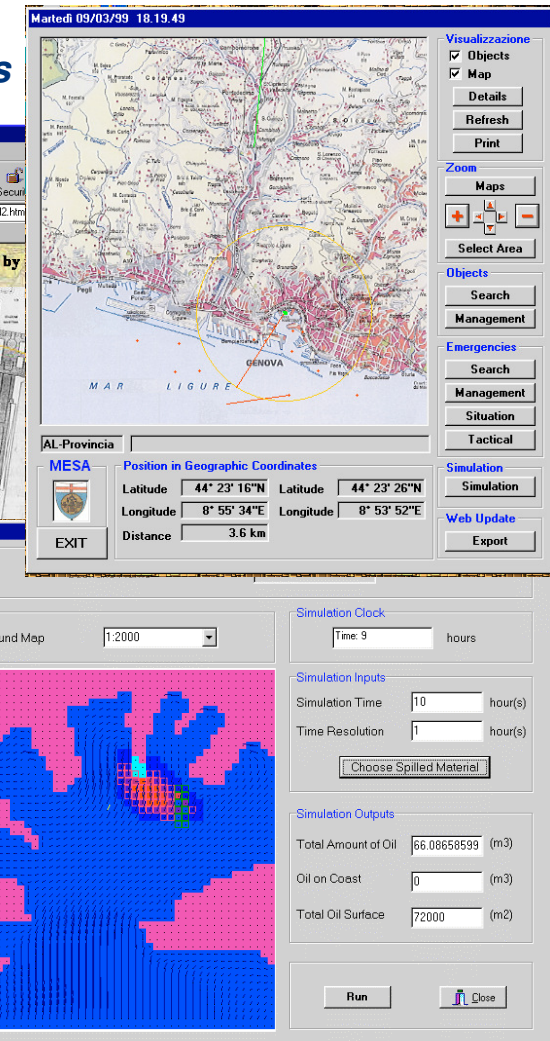
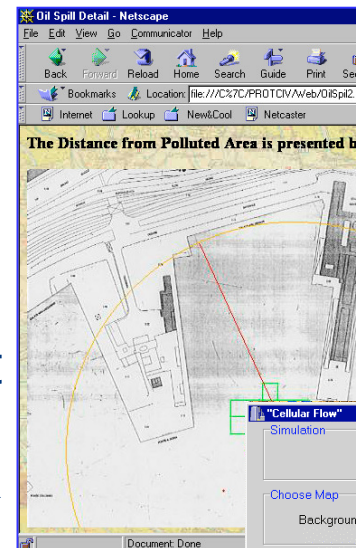



PEDES

PEDEstrian Simulation

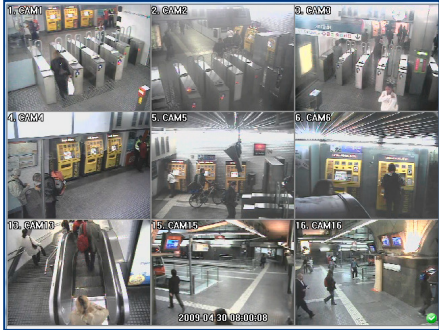

PEDES is a Simulation of pedestrian flows in mass transportation (i.e. underground) devoted to support functional analysis, safety and security solution design and analysis; PEDES is integrated with Human Behavior Models

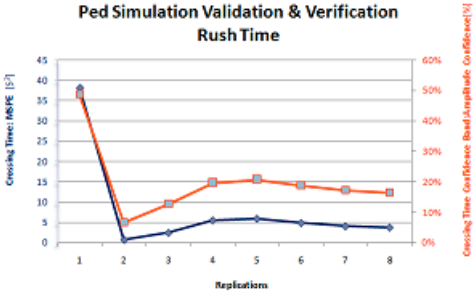
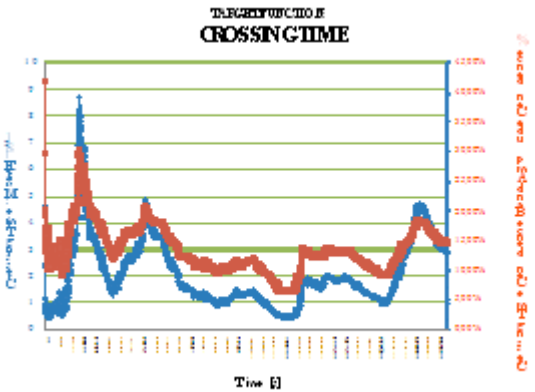
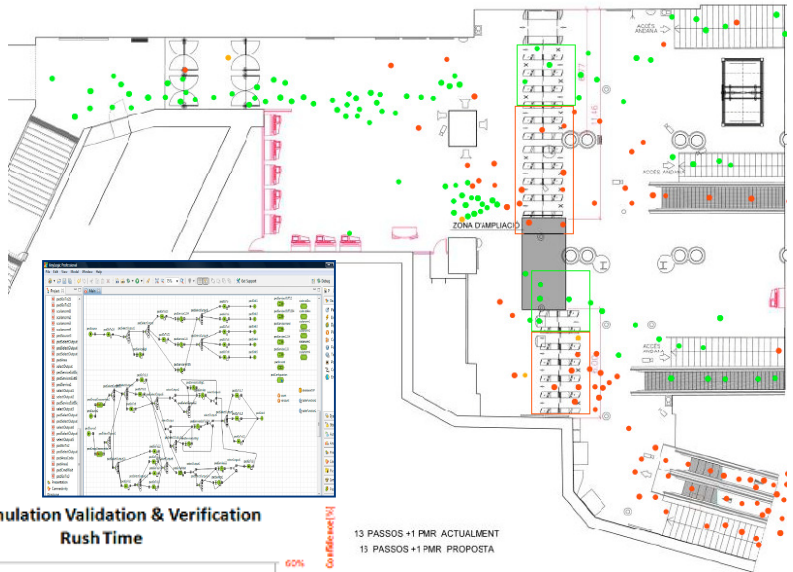

13 PASSOS + 1 PMR ACTUALMENT
13 PASSOS + 1 PMR PROPOSTA





Distributed Virtual Maritime Environment

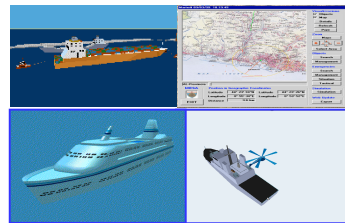

Procedure Design, Risk Analysis , Re-Engineering

**DIS
HLA**

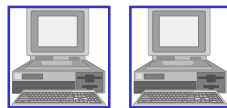

**C/C++
Java**

Distributed , Cooperative Planning and Management

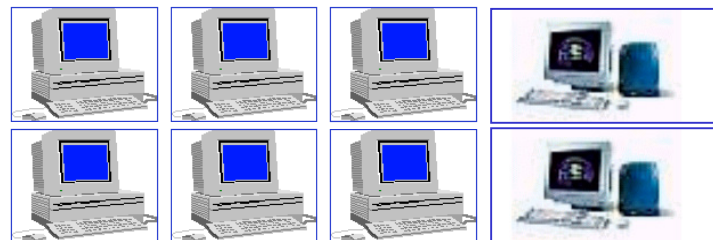

Distributed Operation Control

A Platform Independent Distributed Environment for Maritime Applications





FLODAF

Fuzzy Logic Data Fusion

FLODAF is an tools to support engineering and performance estimation of Data Fusion Solution; this suite includes a Scenario Generator and a Simulator for analyzing the Data Fusion performances over complex Air-Naval scenarios including ships, submarines, missiles, airplanes and helicopters.

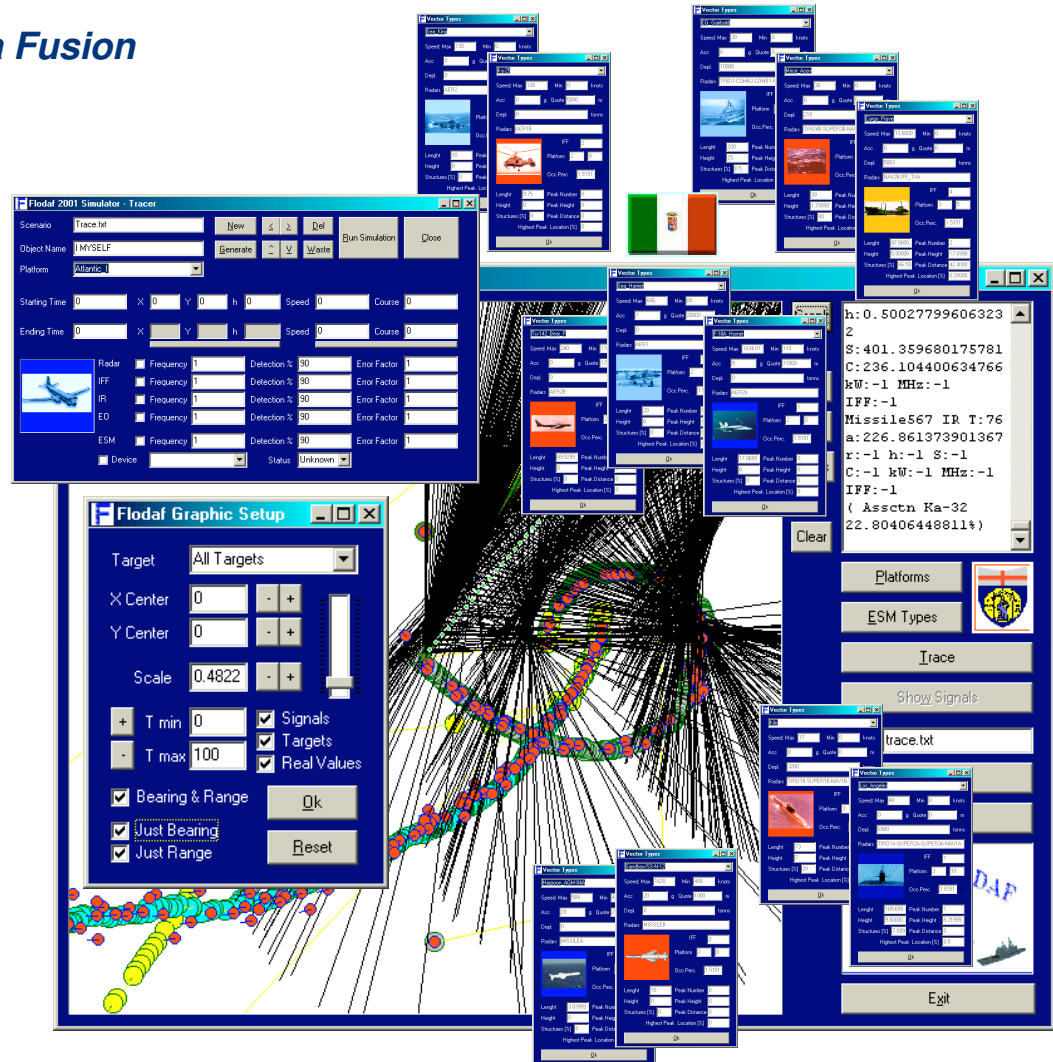



VISION

Virtual Ship Simulation

DIPTM, as reference point in Distributed Simulation and HLA in Italy, was in charge as responsible for defining VV&A procedures in VISION Project devoted to create a Virtual Ship using HLA.

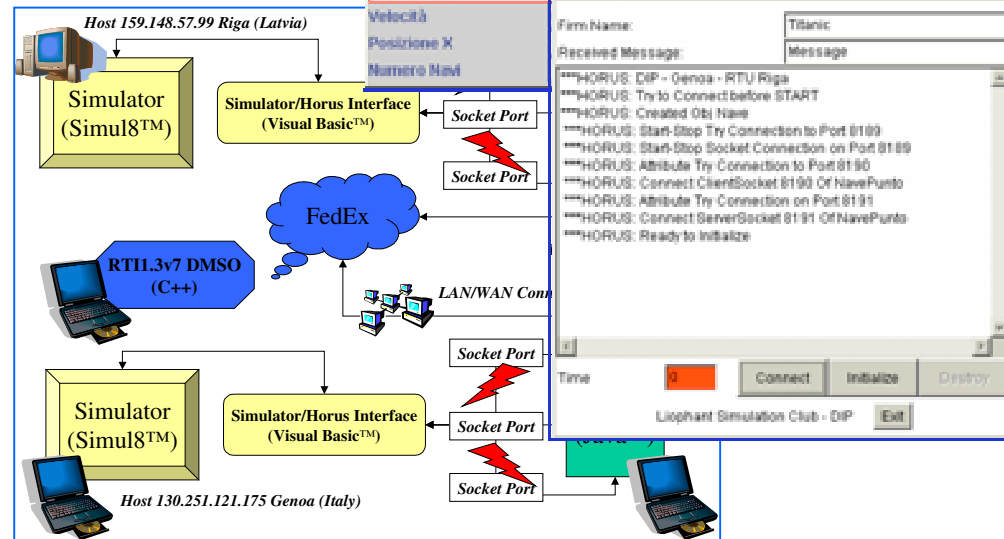



NIAG SG-60

Simulation Based Design And Virtual Prototyping (SBD & VP)



The NIAG SG-60 is devoted to evaluating the effectiveness of SBDVP on Ship Design

The results of the SG60 Study include analysis of Virtual Prototype VV&A procedures, Simulation Based Acquisition impact in terms of saving, costs, resources

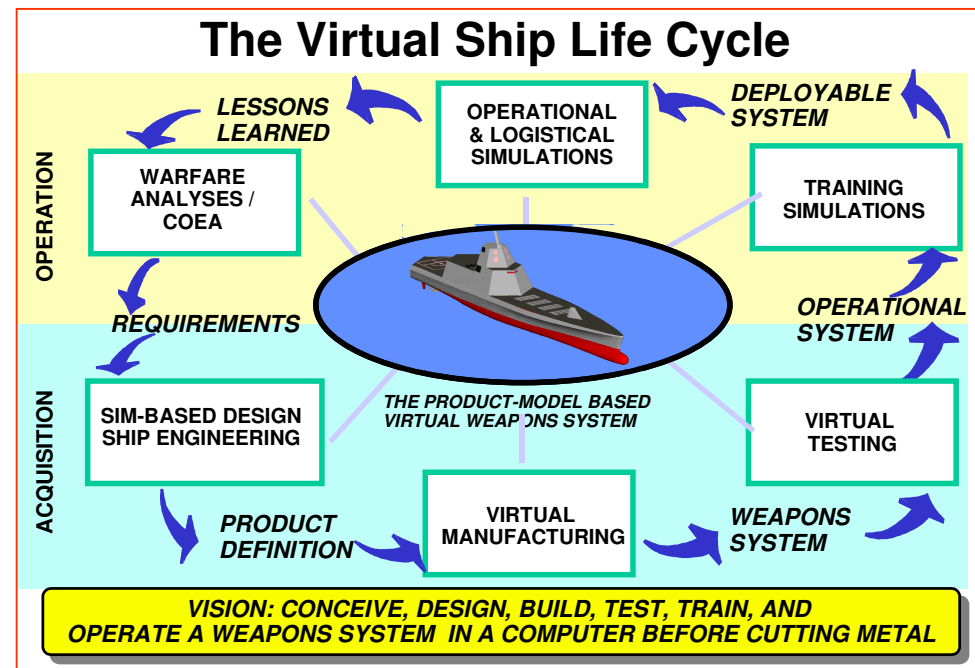



PANOPEA

*Piracy Asymmetric Naval Operation
Patterns modeling for Education & Analysis*

- PANOPEA is a simulator for reproduction of Piracy activities and for evaluating different strategies in NEC C2 M2 (Netcentric Command and Control Maturity Models).
- PANOPEA reproduces military vessels and helicopters, ground base, cargos as well as fisherman and yachts traffic as well as Pirates
- Pirates are directed by Intelligent Agents and apply strategies for succeeding



WSS&S

Weapon System Service & Simulation

This Simulator is devoted to re-engineer Weapon System Logistics and Service.

The Simulator is operating in Taranto Base to support the service planning of Torpedo, Missile, Rocket Launchers and Naval Gun Systems.

The simulator is a web-based stochastic simulator and supports the concurrent service management; the model is object-oriented and the implementation allows to operate directly with regular browsers without any special requirements in term of platform or plug-ins..

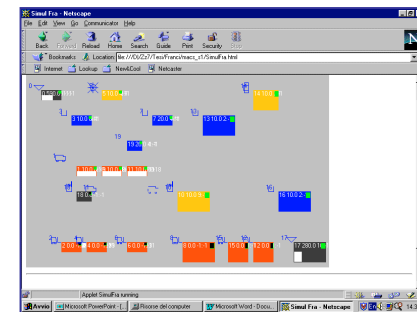
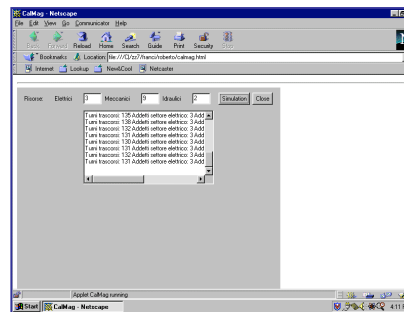
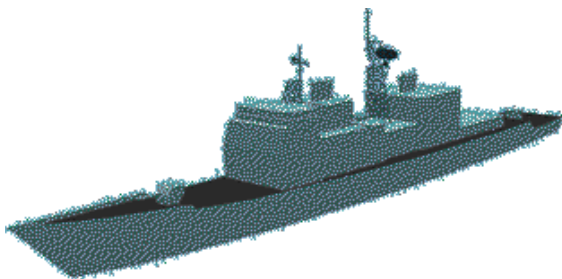



SAFETY FIRST

Training & Design for Ship Handling

The simulator includes a complete virtual reproduction of Genoa Harbor and it's devoted to the design and training of Harbor Technical Services Operators (Pilots, Tugs & Boat Men)

This simulation system is designed in order to be portable for cooperative training on web server just using regular browser with specific plug-in.

- *Full Interactive Real-Time for Training*
- *Faster than Reality for Procedure Design*
- *Virtual Environment of Genoa Port on a PC*





SESTANTE

Simulation Environment for Ship Traffic Analysis, Testing & Evaluation

The project supports the simulation of Maritime traffic in a wide area (i.e. Mediterranean Sea) by using Object Oriented Models.

SESTANTE allows to compute the flows and delays related to strategic investments over ports or maritime lines.

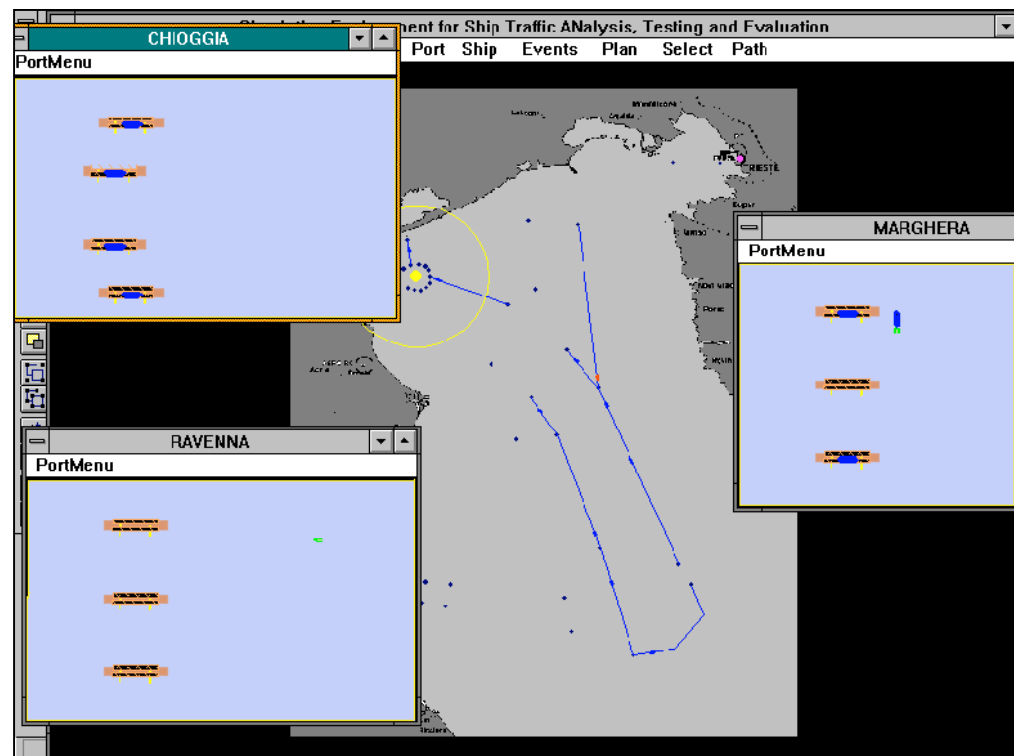
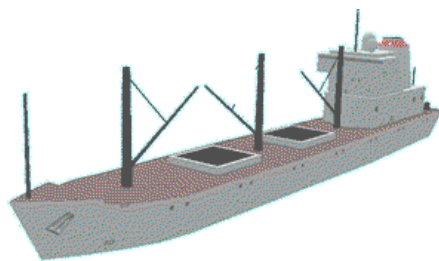



ROSES

Reaction to Oil Spill Emergency and Simulation

The project is devoted to create an Oil Spill Simulator for CETENA including countermeasure models.

The Simulator was validated in relation to historical data available from previous cooperations (i.e. MESA, Kuwait University, etc.) and existing databases (i.e. Istituto Idrografico Italian Navy) in order to guarantee the result fidelity.

Roses reproduces both the oil spill physical phenomena and the countermeasures actions in order to provide estimations about risks, policy effectiveness and standing operating procedures.

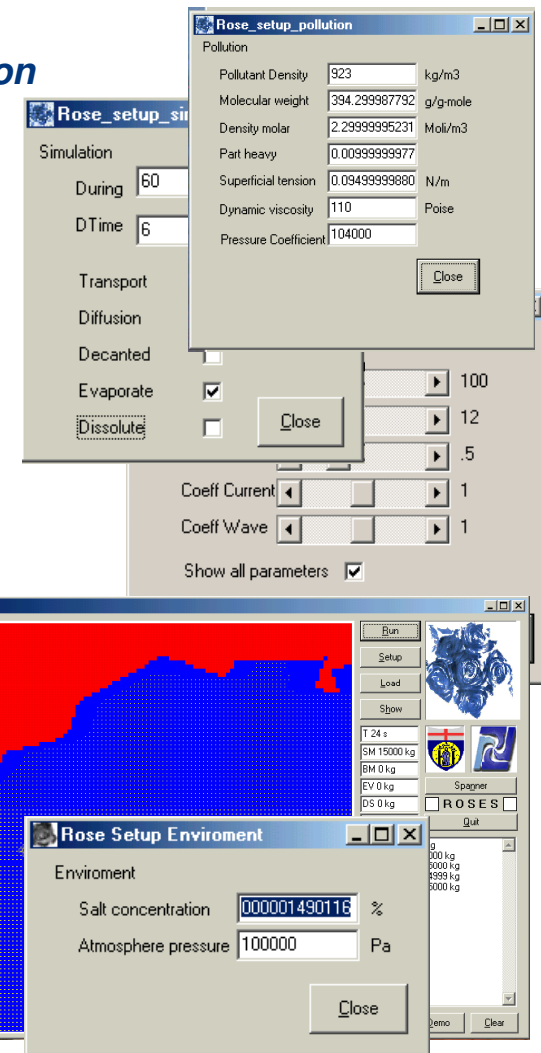



POSEIDON

POrt Simulation Environment for Design of Operation and Network

This Project involves a web based, stochastic & combined (discrete & continuous) simulator.

- **Multedo Oil Terminal Genoa**
- **Vessel Traffic System**
- **Tankers**
- **Docks**
- **Pilot Boat**
- **Tugs**
- **Mooring Men Boats**

Demo is available at:

www.itim.unige.it/liophant/projects/poseidon

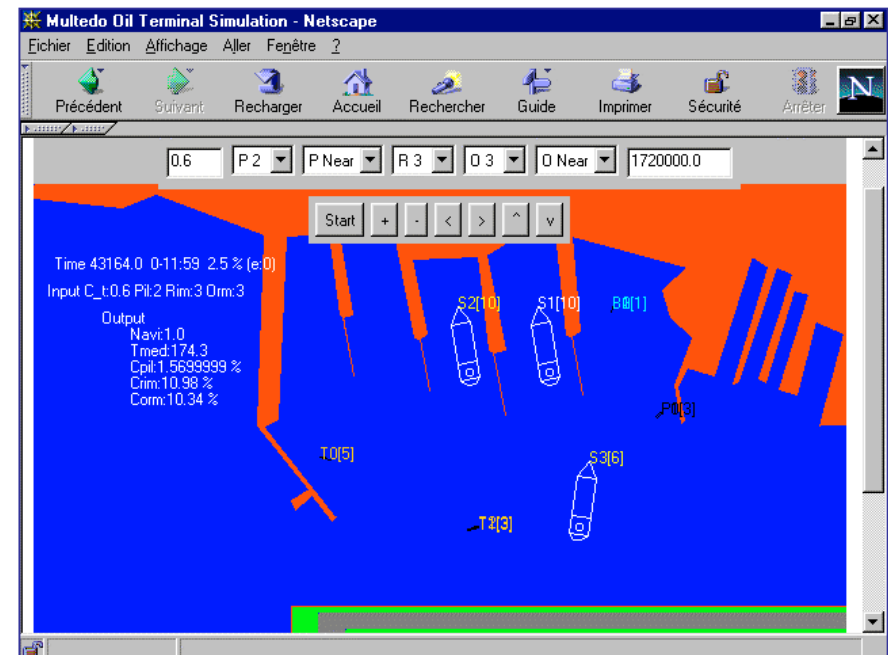



SIMILO

Ship MicroLogistics

The simulator *Similo* (Ship MicroLogistics), is an integrated approach to M&S and VR devoted to support on-board plants and processes; in this case the study focused on the crew mensa (cook-room) in development by CETENA/Fincantieri.

Similo model the interaction among people and his behavior in order to estimate support performance analysis (i.e. evaluation of external catering as substitute of kitchens in Fast Ferries).



Java
Javascript
3DSMax

Vbasic
Maxscript
HTML





Placra

Platform Crew Analyser

The Placra model was developed in order to reproduce the crew activities on Oil Platforms. Placra simulates crew activities

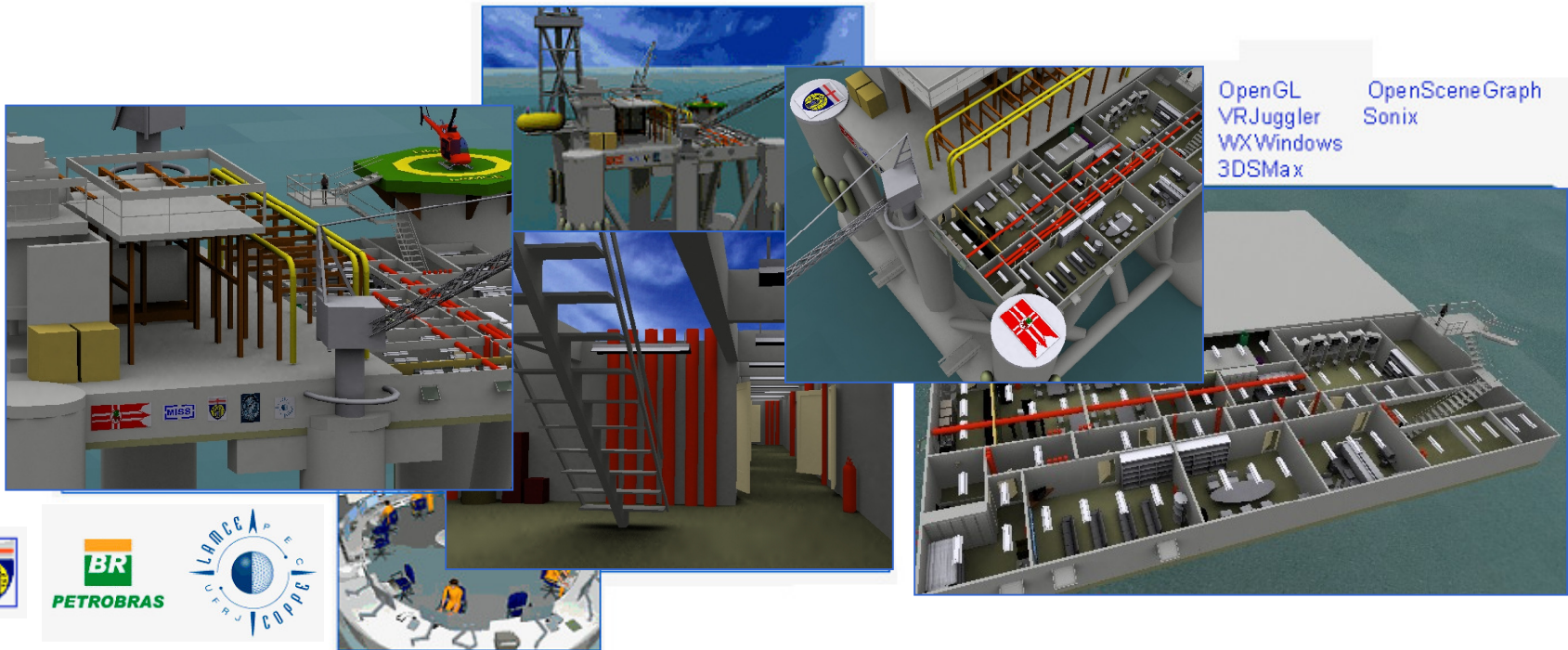



DESU-BUMATRAS

Development Support for Front & Design in Bulk Material Transhipment System

DESU-BUMATRAS provided support to the development, validation of a Stochastic Discrete Event Simulator and on the related analysis on a Bulk Material Terminal & Transhipment Solution involving sea vessels & river barges

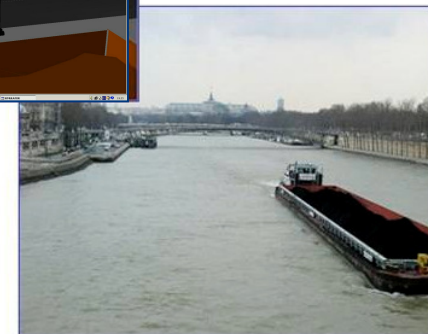
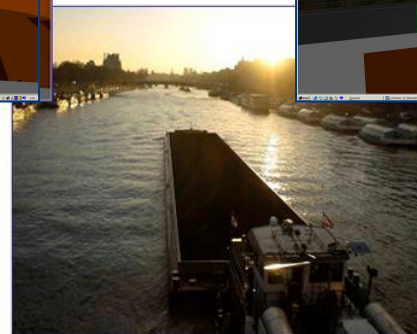
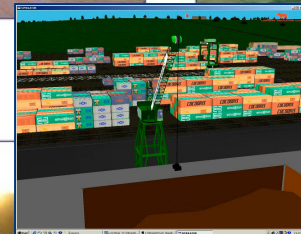
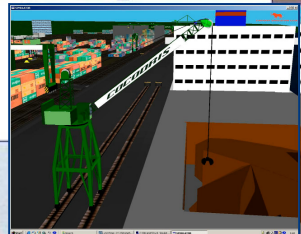



CYBERSAR Portainer Simulator

Cyber Infrastructures for R&D in Sardinia-Portainer Simulator

Portainer Simulator developed as further evolution of DIPTM Engine (Cocodris) by using ST_VP.

The System is devoted to Support Training and Virtual Prototyping by integrating Simulation and Biometrics Device

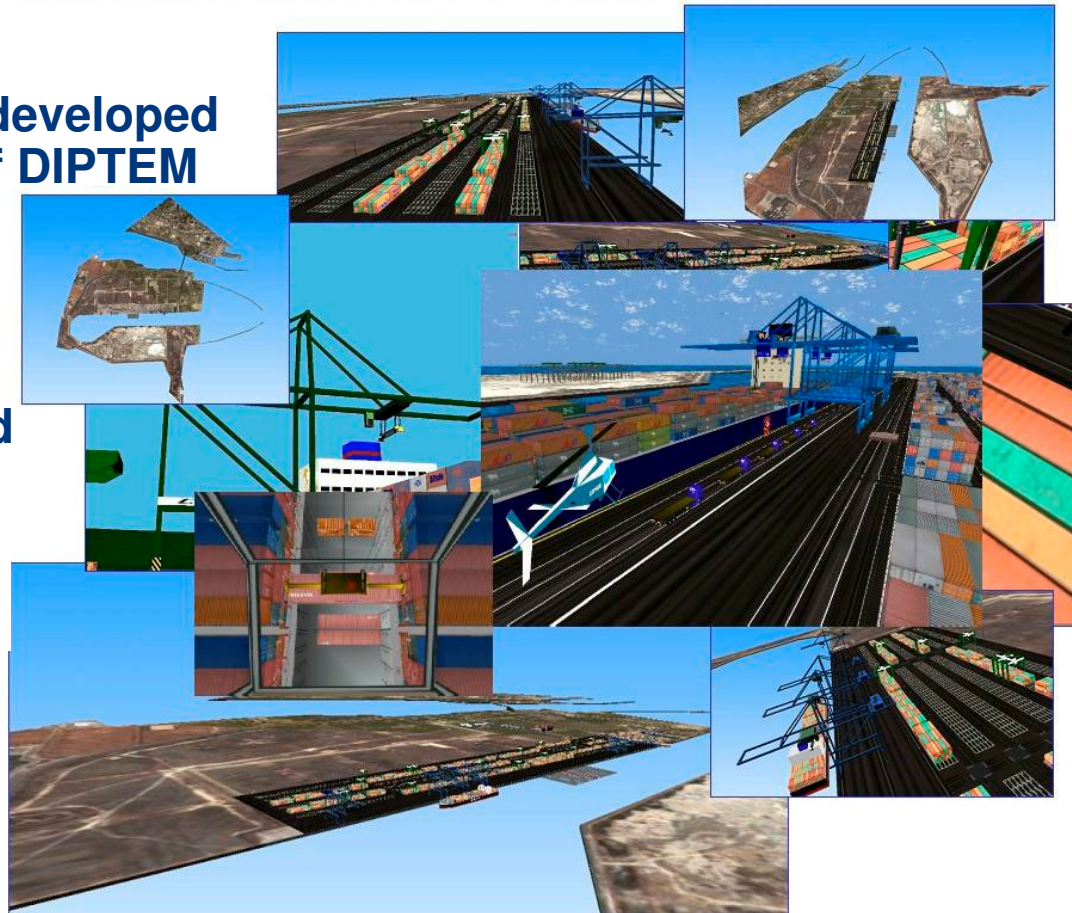



VIP-STRALO

Virtual Prototype by Simulation in Transportation and Logistics

VIP-STRALO goal is the creation of an innovative solution based on Interoperable Simulation for SBDVP (Simulation Based Design and Virtual prototyping) applied to Logistics, Transportation and Automation Sectors.

VIP-STRALO included the creation of two interoperable demonstrators:

- **LOCRAS: Logistics Crane Simulator**
- **FEBO: Federation of Boats**





ProSim

Project Management Simulation System

The project is a joint venture between Genoa University and Fincantieri, the major Italian Ship Yard Construction Company.

The project was tested in relation to their new generation of commercial ships: fast ferries for the car deck systems involving impact of R&D and prototyping issues.

ProSim has been already successfully applied to traditional ship construction problems for military ships and now is fully integrated with existing Project Management Software

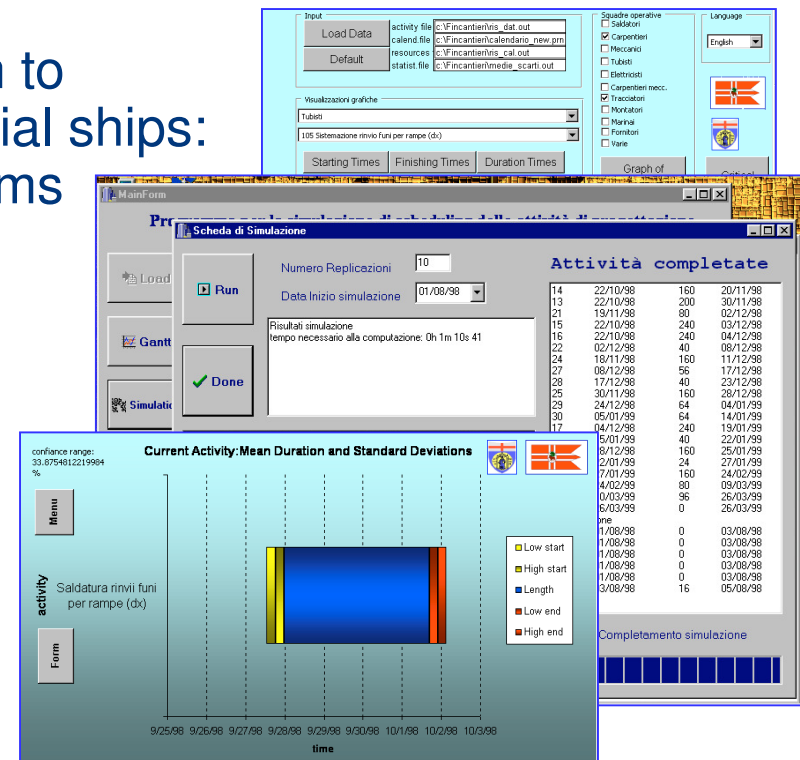



Interoperable Virtual Simulators



The Simulators developed by Simulation Team are an important support in Training both Operative Resources and Decision Makers. The Interoperability of our simulators is based on state of art standards (i.e. HLA High Level Architecture) and emphasize in addition to traditional stand-alone training in Operating, even Concurrent Cooperative Training in Operations and Policies; Simulation Team collect long experience in Professional and Executive Training.





ST_PT & ST_RS Simulators

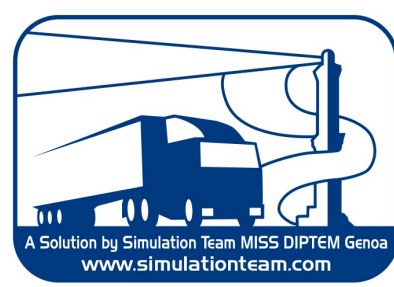
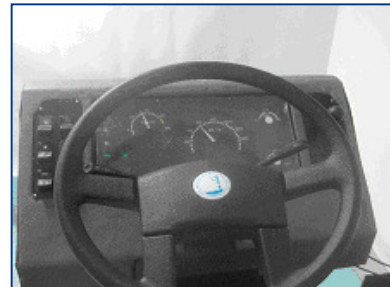
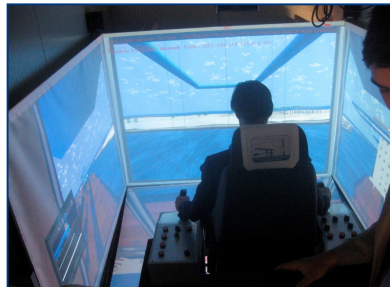
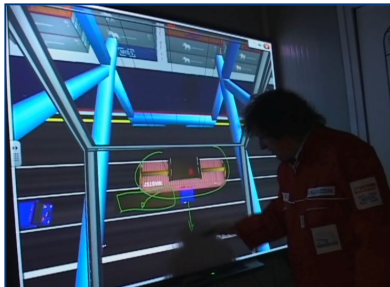
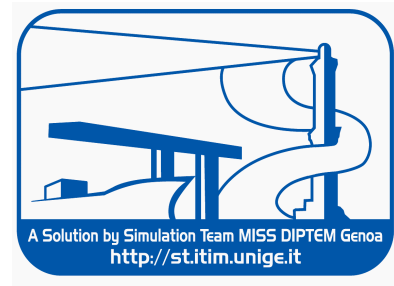

This new generation of simulator is mobile, real-time, scalable and interoperable and compliant with state of art technology and standards

Shelter & Facilities

ST_PT Crane Sim

ST_PT Truck Sim





Atout of our Virtual Simulation

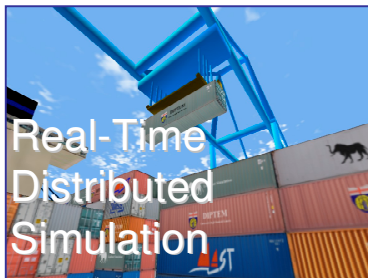
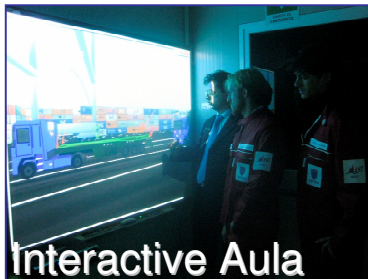



ST_VP: Virtual Port Simulation



The **ST-VP** is the ultimate Port Crane Simulator developed by Simulation Team and includes all the different crane types and New Solutions for Operator Training, Safety and Security, Procedure Definition, Equipment Design and Virtual Prototyping



ST-VP is fully containerized real-time distributed HLA Simulator reproducing Port Operations. ST-VP is integrated in a 40' High Cube Container ready to be used on site immediately after arrival.



ST-VP Simulator allows to operate all the different Port Cranes in a Virtual World by an immersive Cave (270 ° Horizontal and 150° Vertical), reproducing Sounds, Vibrations, Motion in all weather conditions

ST-VP includes a Full-Scope Simulation for Training Operations & Procedures, an Integrated Class Room, the Instructor Debriefing Room, and secondary Interoperable Simulators of all the Port Cranes and a Biomedical Module for Safety, Ergonomic and Posture Enhancement.

ST-VP World is customizable for each Port, Crane & Procedure and Equipment.





ST_VM: Virtual Marine

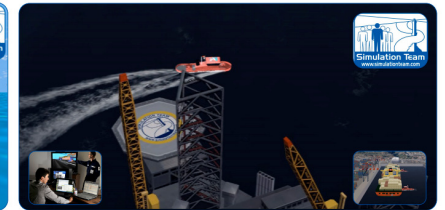
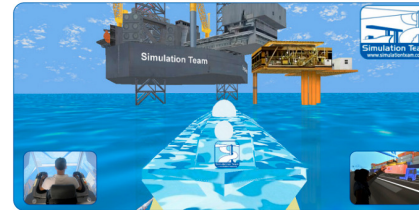

The ST-VM is the ultimate Marine Simulator developed by Simulation Team and includes many different Marine components, equipment and platforms as well as New Solutions for Terminal Design, Operator Training, Safety and Security, Procedure Definition, Equipment Design and Virtual Prototyping

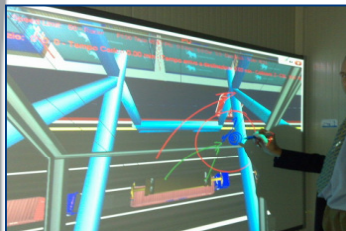

ST-VM is fully containerized real-time distributed HLA Simulator reproducing Port Operations. ST-VM is integrated in a 40' High Cube Container ready to be used on site immediately after arrival.



ST-VM Simulator allows to operate all the different Marine Devices in a Virtual World by an immersive Cave (270 ° Horizontal and 150° Vertical), reproducing Sounds, Vibrations, Motion in all weather conditions

ST-VM includes a Full-Scope Simulation for Training Operations & Procedures, an Integrated Class Room, the Instructor Briefing Room, and secondary Interoperable Simulators of different Marine equipment with other modules (i.e. Biomedical Module for Safety, Ergonomic and Posture Enhancement).

ST-VM World is customizable for each Platform, Port, Crane, Procedure and Equipment.





ST_PT: Port Crane Simulation

The ST-PT is the Gantry Crane Simulator developed by Simulation Team and represents a New Solution for Operator Training, Procedure Definition, Equipment Design and Virtual Prototyping

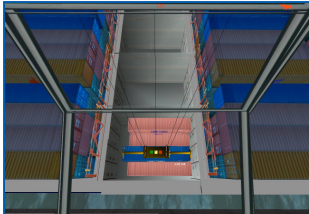

ST-PT is fully containerized real-time distributed HLA Simulator reproducing Port Operations. ST-VP is integrated in a 40' High Cube Container ready to be used on site immediately after arrival.



ST-PT Simulator allows to operate Port Cranes in a Virtual World by an immersive Cave (270 ° Horizontal and 150° Vertical), reproducing Sounds, Vibrations and Motion and all weather conditions



ST-PT includes a Full-Scope Simulation for Training Crane Operations & Procedures, an Integrated Class Room, the Instructor Debriefing Room, and secondary Interoperable Simulators of Trucks and Other Cranes, Biomedical Module for Ergonomic and Posture Enhancement.

ST-PT World is tailorable for each Port, Crane & Procedure and Equipment.

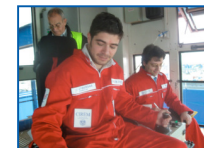



SPM

Smart Polygeneration Micro Grid

SPM is a 7.1M€ EU project devoted to manage efficiently and economically the whole Unige SV Campus systems optimizing contributions coming from renewable sources. SPM is equipped with a grid monitoring system for grid, in charge of checking the functional status of all elements. SPM also includes control and optimization, consumption forecasts, operation planning and real time control of the grid exchange, by regulating generation and consumption units. Sources include: a photovoltaic plant, three solar thermodynamics units and three trigeneration micro-turbines, two natural gas boilers, refrigerating and absorbing plant and electrochemical/thermal storage





ST_RS: Truck Simulation



The **ST_RS** is an Innovative Interoperable Truck Simulator fully integrated with **ST_PT** and Virtual Port; it provides opportunities for Training, Operative Planning and Terminal Procedure Redesign and Re-Engineering

ST_RS is fully containerized real-time distributed HLA Truck Simulator with Port & Inland Terminal and External Scenarios. **ST-RT** is integrated in a 40' High Cube Container ready to be used on site immediately after arrival.

ST_RS Simulator allows to operate Trucks in Terminal and over External Roads within a Virtual World by an immersive Cave (270 ° Horizontal and 130° Vertical), reproducing Sounds, Vibrations and Motion.

ST_RS includes a Full-Scope Simulation for Training Truck Driving, Logistics Procedures, an Integrated Class Room, the Instructor Debriefing Room, and secondary Interoperable Simulators of Different Cranes Cranes, Biomedical Module for Ergonomic and Stress Level Enhancement.

ST_RS World is tailorable for each Terminal Scenario, Truck, Procedure and Equipment.





CTrain

Serious Games to Train Operators into Military Logistics for Overseas Operations

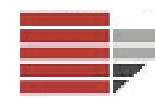

CTRAIN is a serious game devoted to train Operators into Military Logistics for Overseas Operations. CTRAIN is project developed in cooperation by University of Calabria, MSC-LES, CAL-TEK and University of Genoa under the umbrella of the Simulation Team.

CTRAIN makes use of interoperable simulation for providing its user with a distributed virtual environment in which different types of operators can be trained with cooperative sessions.

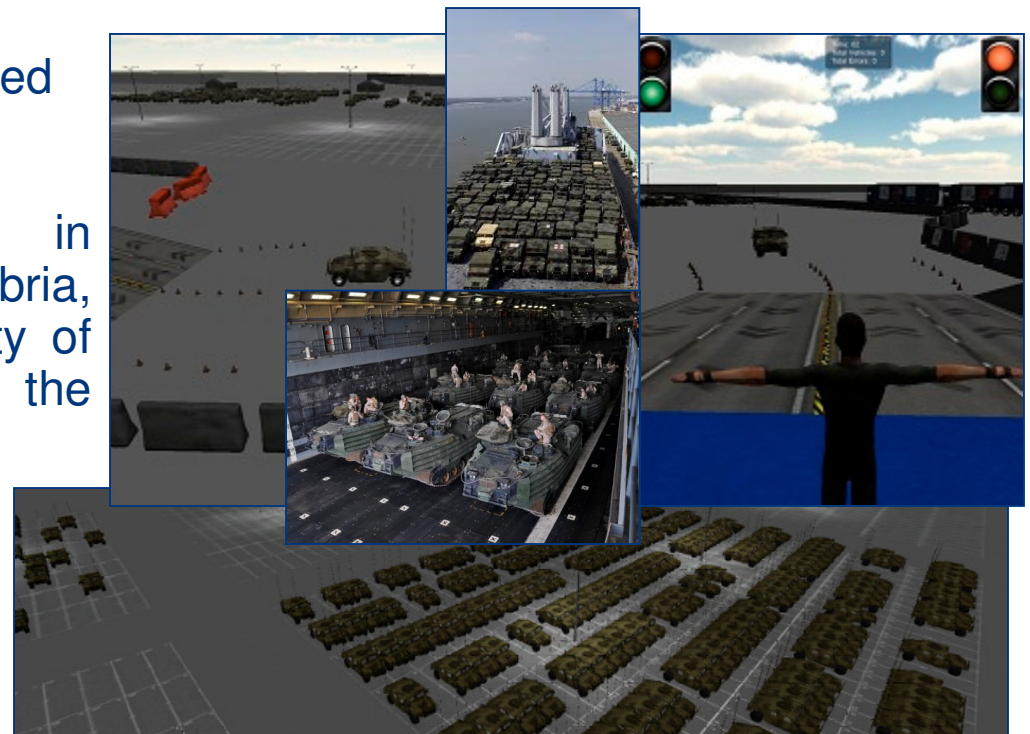

www.sim4future.com/cloud_1.html





CTSim

Serious Game for Ro-Ro Operations



CTSIM is a research project developed by University of Calabria, MSC-LES, Genoa Univ. and CAL-TEK under the umbrella of Simulation Team. CTSIM can be used to train operators working in car terminals with particular attention to drivers, marshalls, quality checkers and tally men.

The CTSIM architecture is based on interoperable simulation and makes use of dedicated external hardware (i.e. motion controllers, virtual immersive helmets, wheel, pedals, etc) to provide users with the sensation to be in a real car terminals.

Multiple scenarios are available in terms of different terminal layouts (based on real existing terminals), multiple vehicles (i.e. cars, trucks, buses, etc.) and multiple types of available operators.

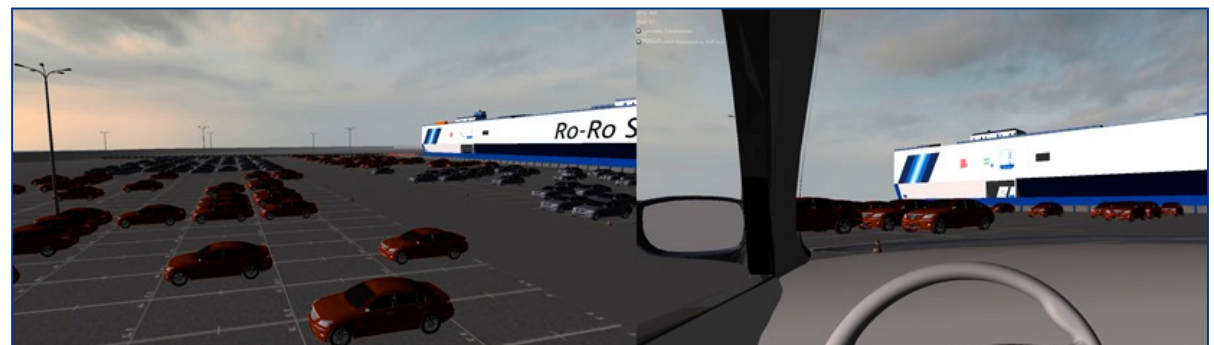

www.sim4future.com/cloud_1.html





DEMON

DEsign of port facilities for boat Manufacturing Operations in the Nautical sector

A business plan for correctly designing a port facility devoted to manufacture and store boats has been developed. The business plan starts with the analysis of the International and National shipbuilding markets and then narrows down to the Calabria Region one. All the port facilities within Calabria have been analyzed and evaluated; this analysis has brought to the correct identification of the optimal location for setting up the port infrastructure. The port plant layout has been designed and economic and financial analysis have been carried out.





RESET

River Equal Ship Simulation in Extensive Training

RESET is a project, devoted to creating a Federation for supporting training in river navigation and logistics. The Simulators includes:

- Barges
- Tanks

The RESET Federation includes the river dynamics for reproducing the maneuvering in condition affected by different streams, variable deep.



STICEL



Log.In.Form.





INNOVARE

Sviluppo Intermodale Novara e Vercelli Abilita' Risorse Umane - Equal

INNOVARE is a project, devoted to creating a Federation for supporting cooperative and competitive training in hinterland terminals. The Simulators includes:

- Reachstacker Simulator
- Truck Simulator
- Transtainers

The INNOVARE Federation is centered on the Rail Terminal Simulation and CM operations.



STICEL

Log.In.Form.



autovictor



DIPTM
Università di Genova



Virtual Prototyping



The Simulation Team Solutions are very effective as support for Virtual Based Design and Prototyping measuring Real Overall Performances in the Virtual World by considering dynamic interactions among all the Elements and Entities.

Experience was carried out in Equipment, Control and Man-Machine Interface Re-Engineering

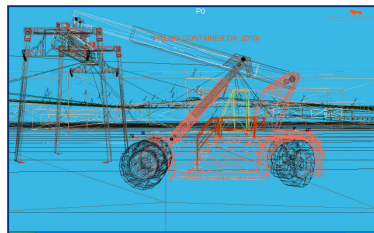
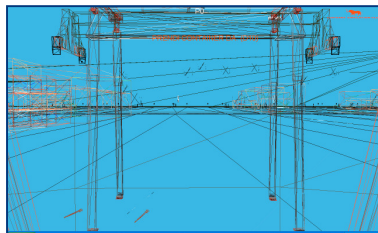



SITRANET

Simulation for TRAINiNg & Education in Transportation

SITRANET is a project sponsored by EC, devoted to creating three simulators as training equipment for crane operators based on Virtual Reality.

The Simulators includes:

- Special Crane Simulator
- Contstacker Simulator
- Truck Simulator

The project technology leadership is assumed by DIPTM. The SITRANET Simulator validation and verification involved over hundreds professional truck drivers and crane operators





Virtual Degenerative Operator Conditions

Simulation Team Solutions is proposing to start up a new project for Modeling the Degenerative Perception of Humans in Critical Conditions combining Simulation and Biomedical Measures. The Goal is to reproduce the Operator Perception under high stress or fatigue, or upon drug/alcohol abuse for creating a Virtual Framework devoted to develop possible MMI Aids and support definition of policies and regulations

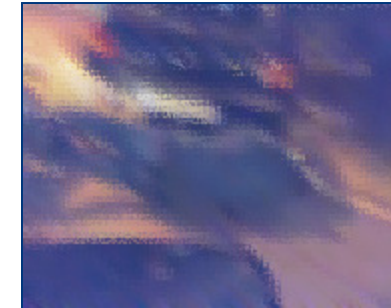
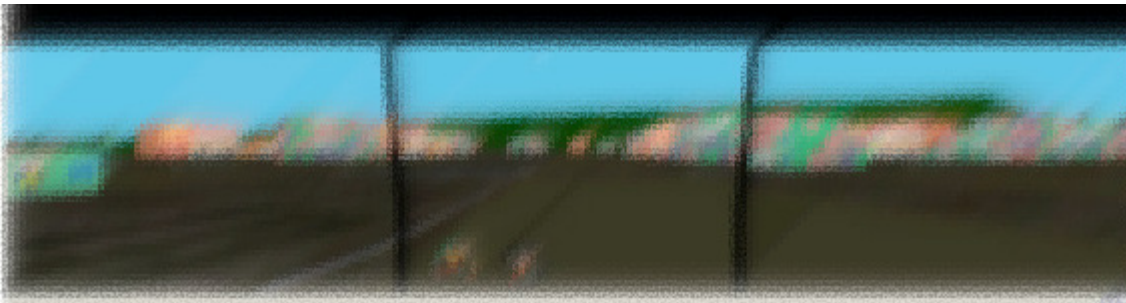



Virtual Security Assessment and Training



VISAT (Virtual Security Assessment and Training) allows to Simulate Security Issues in Complex Framework such as that one related to Port Environments.

VISAT includes Constructive Sim of organizations and layouts as well as Synthetic Environment for Virtual Sim supporting Distributed Cooperative Training among different Actors (i.e. Port Authority, Coast Guard, Custom Resources, Terminal Operators, Public Urban Authorities) within different Scenarios

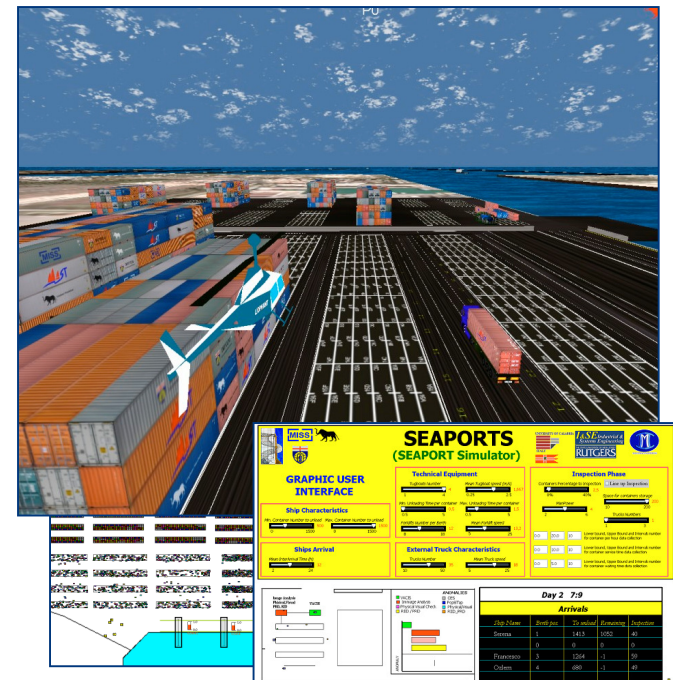



Port/Terminal Security Simulation



Simulation Team is active in Modelling & Simulation for Guaranteeing Security in Maritime Environment especially in reference to Ports and Terminals

A major goal in this context it is to create solutions that support the Definition of operative and training procedures for security and safety harbours operations with strong emphasis on common standards and multi user framework

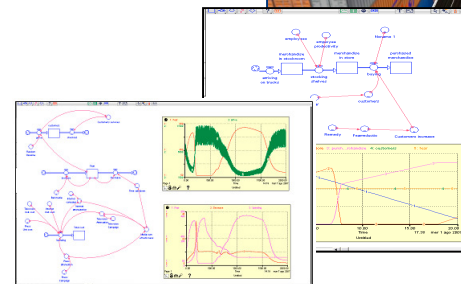
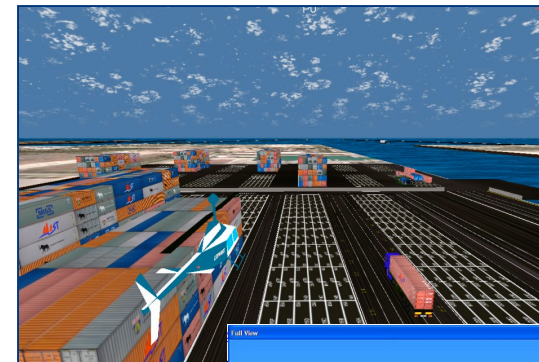



GreenLog Simulators



Simulation Team developed GreenLog Simulators for Analyzing Production, Logistics and Supply Chain.

GreenLog is a Web Based Simulation Engine devoted to evaluate Costs and Environmental Impacts of Productive, Logistics and Transportation Elements of the Supply Chain and Specific Modules have been developed for focusing on specific aspects:

- GreenLog Port
- GreenLog Ship
- GreenLog Crane
- GreenLog Warehouse
- GreenLog Train
- GreenLog Air
- GreenLog Heavy Haul





GREENLOG Project

Green Logistics Project

GreenLog is a web framework combining simulation and analysis techniques for self evaluating the Supply Chain efficiency in term of Costs, Quality and Environmental Impact. The GreenLog was developed by Simulation Team DIPTM for supporting a Joint Venture on Green Logistics coordinated by Assologistica in cooperation with several major production, logistics and distribution companies operating in Italy

http://st.itim.unige.it/greenlogistics

Assologistica

CAMPARI

Mars

SONY

CRAI

coop

DHL





GREENLOG Port

GreenLog Port Simulator

GreenLog Port is a specific Simulation Module devoted to support estimation of Environmental Impact in Ports

- Garbage & Port Waste
- Dredging
- Dust
- Noise
- Ship Air Emissions
- Air Quality
- Hazardous cargo
- Bunkering
- Port development
- Ship Discharge



*Developed in Cooperation
with Simulation Team & DIPTM*





GREENLOG Ship

GreenLog Ship Simulator

GreenLog Ship is a specific Simulation Module devoted to analyze the Environmental Impact of the Ship for supporting monitoring, alternative evaluation, saving and benefits from different solution in use, handling, operating as well as in Ship Design GreenLog Ship Includes Air Emission, Consumption, Ship Paints, Garbage/Waste Disposal, Noise, Ship Discharges, Hazardous Cargo, Spills

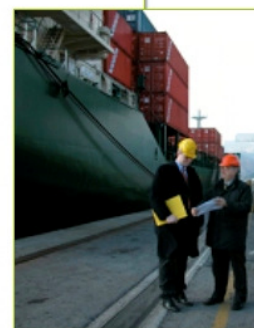
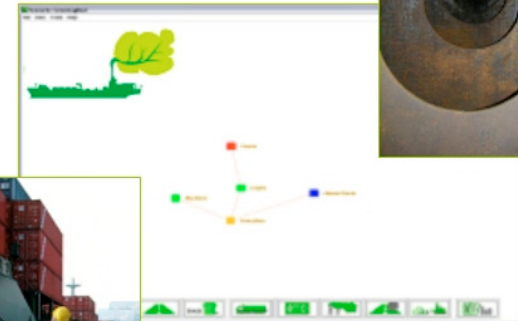

*Developed in Cooperation
with Simulation Team & DIPTM*





GREENLOG Crane

GreenLog Crane Simulator



GreenLog Crane is a specific Simulation Module devoted to analyze the Environmental Impact of Cranes and Handling Devices considering Operative Costs and Environmental Impact. GreenLog Crane allows to estimate the benefits provided by innovative solutions in terms of power saving, oil spill reductions, better safety procedures and higher performances.

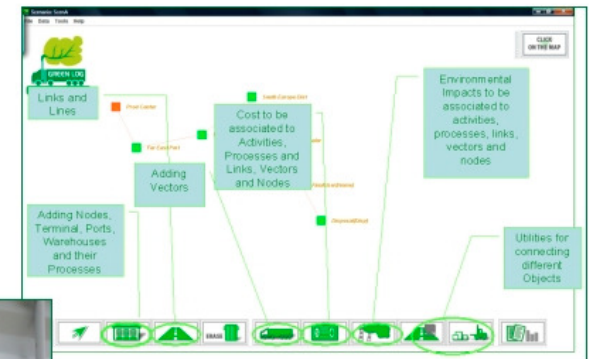

*Developed in Cooperation
with Simulation Team & DIPTM*





GREENLOG Heavy Haul

GreenLog Heavy Haul Simulator



GreenLog Heavy Haul is a specific Simulation Module devoted to analyze the Environmental Impact of Trucks and Heavy Hauls considering Operative Costs and Environmental Impact

GreenLog Heavy Haul allows to estimate the benefits provided by innovative solutions in term of oil and gas consumption, tires, better safety procedures and higher performances



Developed in Cooperation with Simulation Team & DIPTM





GREENLOG Warehouse

GreenLog Warehouse Simulator



GreenLog Warehouse is a specific Simulation Module devoted to analyze the Environmental Impact of Warehouse and Logistics Platforms considering Operative Costs and Environmental Impact. GreenLog Warehouse allows to estimate the benefits provided by innovative solutions in term of reefer solutions, infrastructures, power generation, handling devices & equipment, management policies and control systems.

*Developed in Cooperation
with Simulation Team & DIPTM*

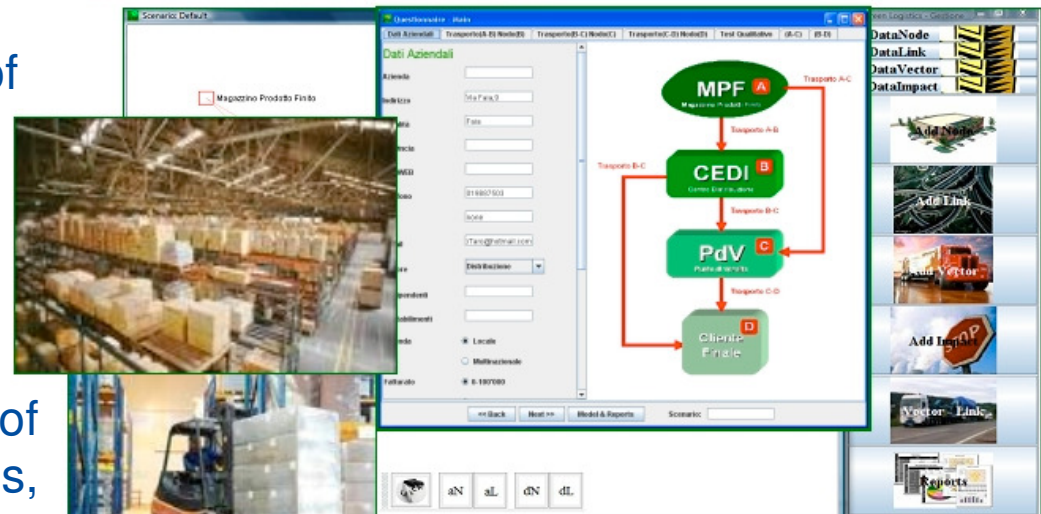



GREENLOG Train

GreenLog Train Simulator



GreenLog Train is a specific Simulation Module devoted to analyze the Environmental Impact of Railways and Trains considering Operative Costs and Environmental Impact. GreenLog Train allows to estimate all the different direct and indirect environmental impacts as well as the benefits from innovative solutions in term of power saving, waste reductions, better safety procedures and higher performances.

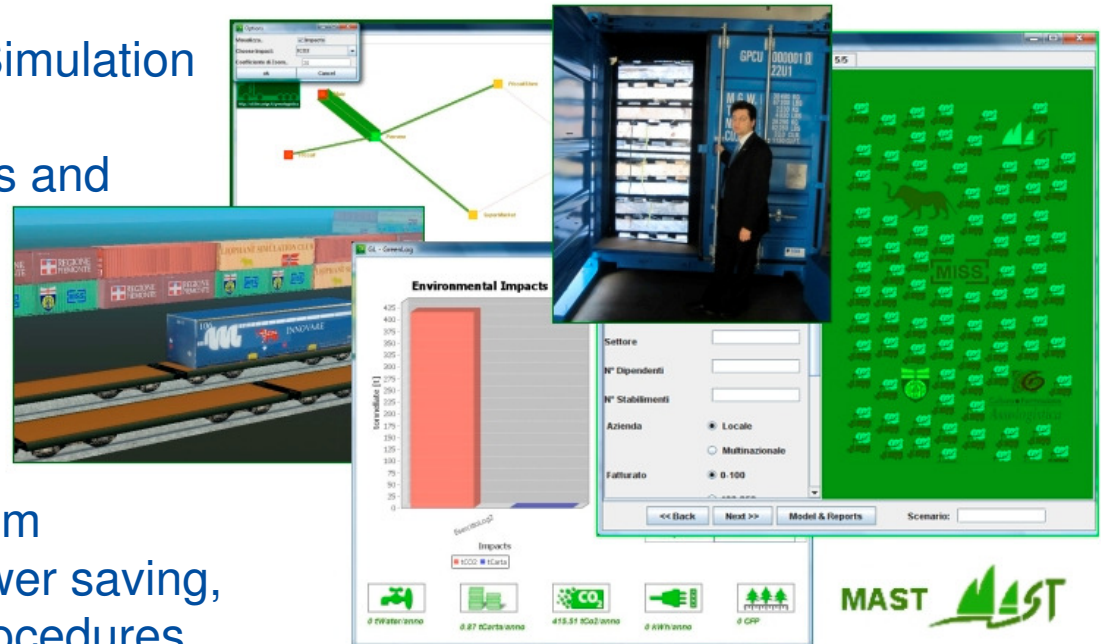

*Developed in Cooperation
with Simulation Team & DIPTM*





GREENLOG Air

GreenLog Air Simulator



GreenLog Air is a specific Simulation Module devoted to analyze the Environmental Impact of Airports and Planes considering Costs and Environmental Impacts both of commercial and cargo operations. GreenLog Air allows to estimate all the different direct and indirect environmental impacts as well as the benefits from innovative solutions in term of management policies, power saving, consumption reduction, waste reductions, safety & security procedures and higher performances

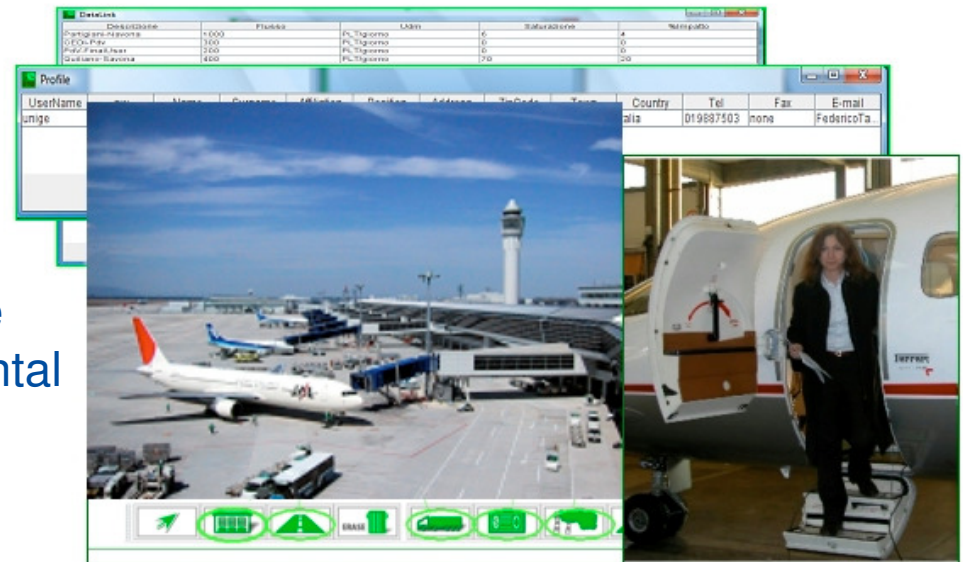

*Developed in Cooperation
with Simulation Team & DIPTM*





LAPIS

Lean Advanced Pooling Intelligent optimizer & Simulator

LAPIS is an intelligent decision support system for Service Division of Construction and Engineering Companies. LAPIS combines different modules:

- Service Model
- Inventory Optimizer
- Scheduling Optimizer
- Overall Resource Optimizer
- Metrics & Key Performance Indexes

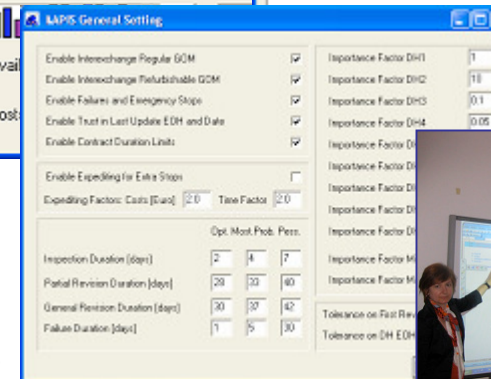
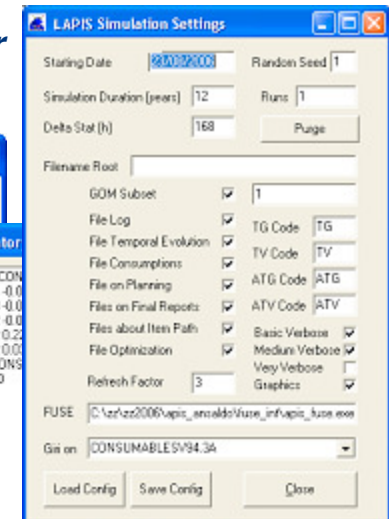
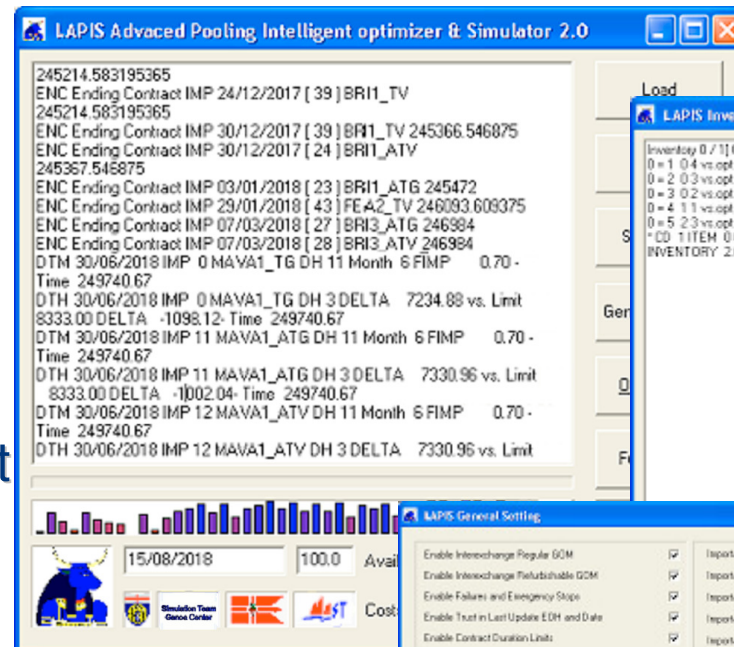



LEXIS

Layout Excellence Integrated Simulation



Developed in Cooperation with DIPTM University of Genoa

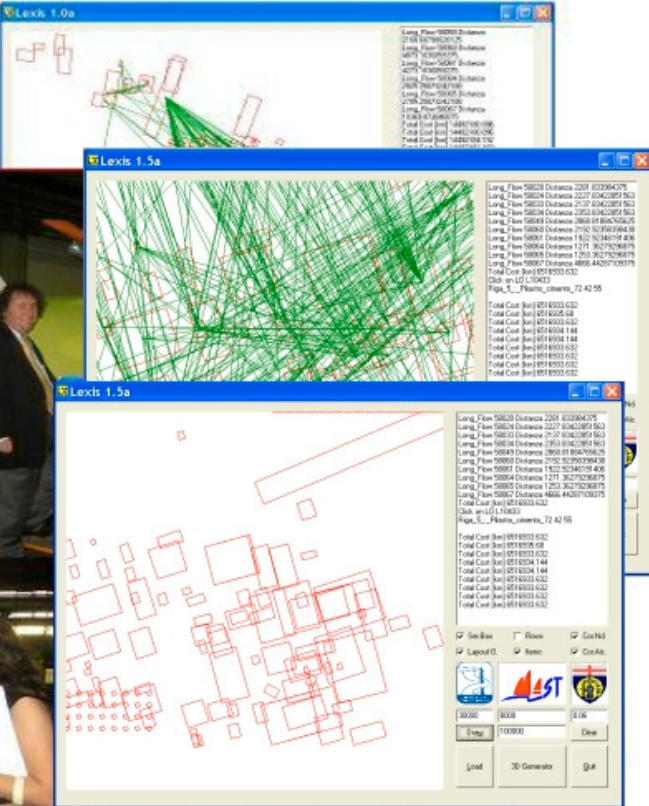

LEXIS (Layout Excellence Integrated Simulation) integrates Layout Optimization based on Genetic Algorithms, Modeling & Simulation and Virtual Reality. LEXIS was applied with success to new large Production Facility for Aerospace Industry. The system allows to consider costs, distances, times and all different production processes and internal and external logistics solutions

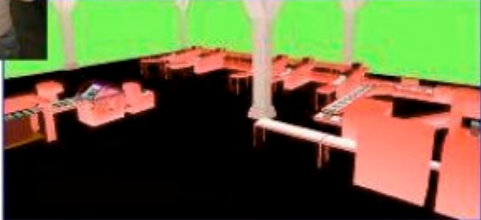
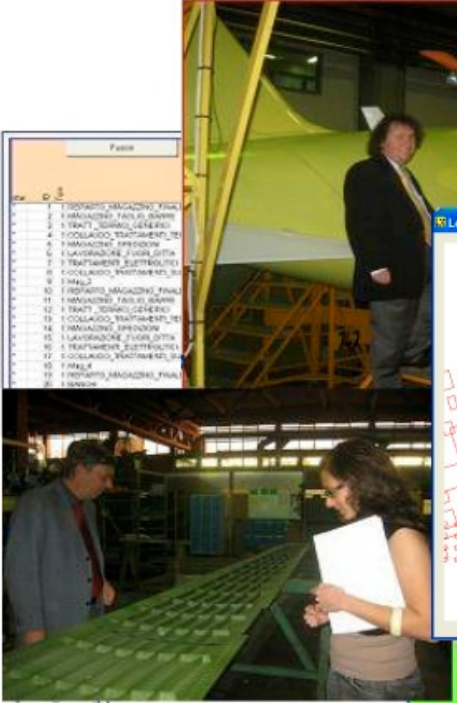



LEXIS for Constructions



LEXIS (Layout Excellence Integrated Simulation) represents a solution for Optimizing Space, Planning and Operations in Constructions even considering the sequence of actions and the use of the equipment on the Construction Yard.

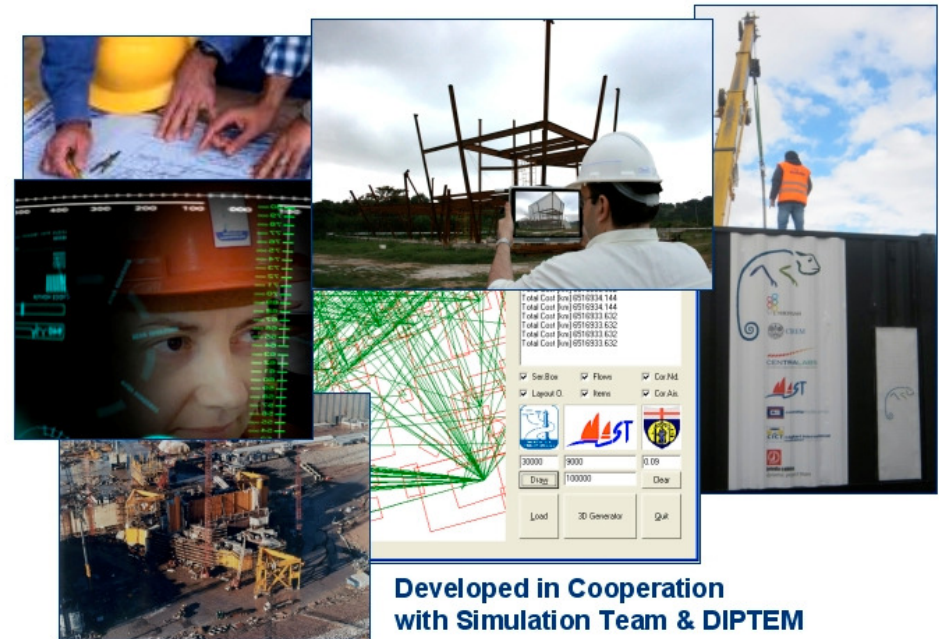

Developed in Cooperation
with Simulation Team & DIPTM



LEXIS for Ship Yard Constructions



LEXIS (Layout Excellence Integrated Simulation) represents a solution for **Optimizing Space, Planning and Operations in Ship Yard Constructions** as well as its management.

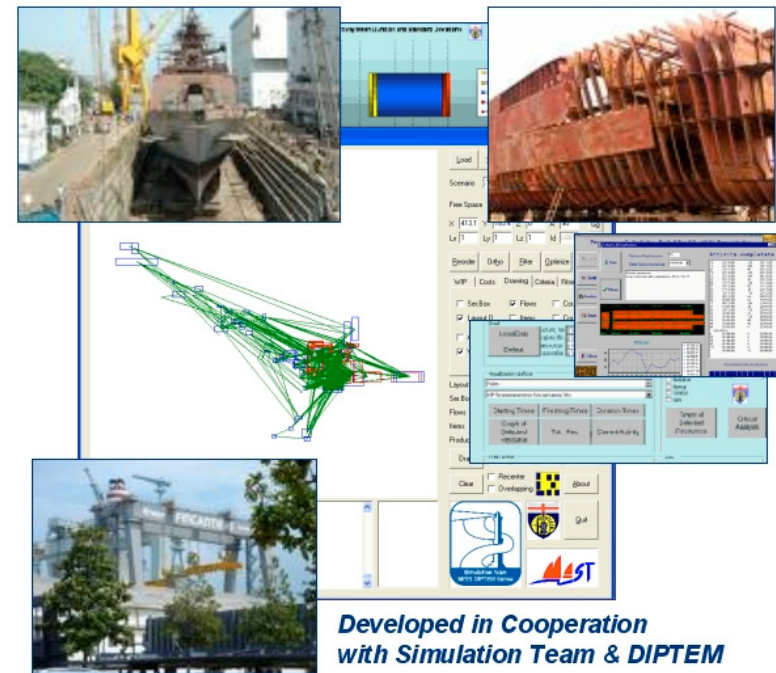

Developed in Cooperation with Simulation Team & DIPTM



LEXIS for Port Terminals



LEXIS (Layout Excellence and Integrated Simulation) represents a solution to Optimize Terminal Layout and Area Assignments by combining a Smart Optimization Framework with an Interactive Dynamic Simulation of the Processes.

LEXIS includes possibility to consider external areas and outsource services



Developed in Cooperation with Simulation Team & DIPTM



Email: info@mastsrl.eu

URL: www.mastsrl.eu



DIPTM
Università di Genova



VELA

Virtual Environment, Live systems and Augmented reality

VELA, Virtual Environment, Live systems and Augmented reality, is an innovative approach that allows by using new technologies to improve Safety through Virtual Environments, Augmented Reality & Phenomena Simulation. VELA is an approach to support:

- Safety & Security Assessment
- Training
- Operational Support



Developed in Cooperation
with Simulation Team





Frine

Forecasts Robust Intelligent Evaluator

FRINE is a modular approach for supporting inventory management, purchasing and outsourcing planning in telecommunication production industry.

FRINE includes: Frine Sim a detailed simulator for evaluating different scenarios, Frine ANN an intelligent forecast system based on Artificial Neural Networks and Commercial Data Fusion and a Frine Metrics for on-line performances measuring and controlling.





VAED

Virtual Aided Engineering & Design

VAED is a joint cooperation between Genoa University and Ansaldo for the development of Distributed Synthetic Environment for Power Plant Design.

A prototype has been developed and used for supporting design of Burners, Piping, DCS of a Gas Turbine in joint project with Siemens.

A set of demonstrators has been implemented and tested to support Project Management applied to these projects.



ANSALDO

Building	Ingegneria	Fornitura	Montaggio	Avviamento
Electrical Boards				
Medium Voltage				
Low Voltage				
UPS (Uninterruptible Power)				
Distrib Control System (DCS)				
Cable Trays				
Cable Pulling				
Cables				
Civil Works				
Found				
Steel Struct				



COUGAR

Controller & Organizer for Ultimate Government of Availability and Reliability

COUGAR is the innovative system for the Service and Maintenance of complex systems (i.e. Helicopters). The system is designed to satisfy the requirements connected with the maintenance management of helicopters taking care of both pre-planned and emergency actions.

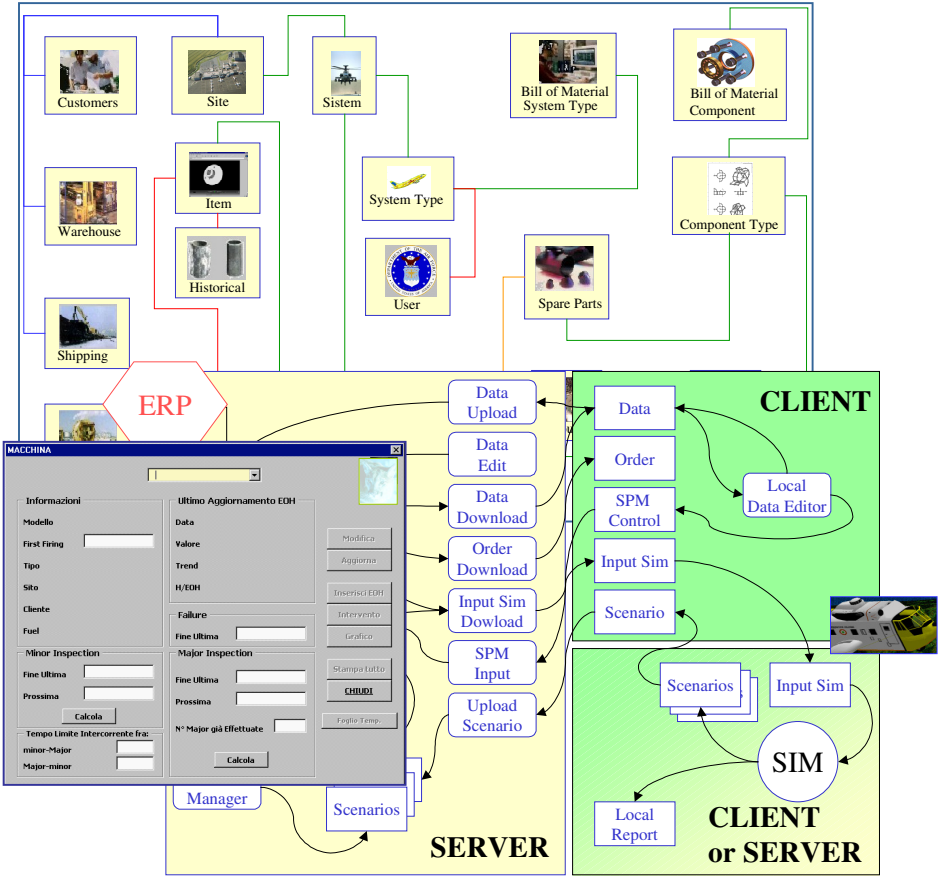



PUMA

Project for Ultimate MAintenance

PUMA is the innovative system for re-organizing Gas Turbine Service in Ansaldo Energia. The system allows to manage resources, spare parts, internal/external warehouses, shipping and scheduling of all the maintenance operation for over 50 power plants distributed world-wide.

The screenshot displays the PUMA software interface with several overlapping windows:

- PUMA DATA SERVICE:** The main dashboard with a grid of icons for CLIENTI, STORICO, ORDINI, SITI, ITEM, MAGAZZINI, TIPI, and MACCHINA. A SIMULATORE icon is at the bottom.
- ASSE MACCHINA:** A window titled 'SELEZIONE ASSE:' with a dropdown menu showing 'MIRFA_TG643'.
- PUMA Simulator:** A detailed configuration window with the following data:

Onese Magazzino Ansaldo.....(Lit/Mese)	12087414	Giorni:	36748	Data:	10/8/2000
Onese Magazzino Siti.....(Lit/Mese)	34607512	<input type="checkbox"/> BALLYLUMFORD1	<input type="checkbox"/> JEBELAL17	<input type="checkbox"/> JEBELAL18	<input type="checkbox"/> LIBERTY
Onese Pezzi in Viaggio.....(Lit/Mese)	6681925	<input type="checkbox"/> BALLYLUMFORD2	<input type="checkbox"/> BALLYLUMFORD3	<input type="checkbox"/> BARRY	<input type="checkbox"/> MEGHNAGAT
Costo Pezzi Installati.....(Lit/Mese)	12310192	<input type="checkbox"/> BEDDAWI2	<input type="checkbox"/> CARRASCO1	<input type="checkbox"/> CARRASCO2	<input type="checkbox"/> MIRFA1
Costo Handling.....(Lit/Mese)	51250298	<input type="checkbox"/> CASSANO	<input type="checkbox"/> CHANIA1	<input type="checkbox"/> CHANIA2	<input type="checkbox"/> FERRARA1
Costo Spedizione.....(Lit/Mese)	37429912	<input type="checkbox"/> FERRARA2	<input type="checkbox"/> GHANA1	<input type="checkbox"/> GHANA2	<input type="checkbox"/> ISAB1
Costo Stock - Out.....(Lit/Mese)	25239000	<input type="checkbox"/> ISAB2	<input type="checkbox"/> JEBELAL15	<input type="checkbox"/> JEBELAL16	<input type="checkbox"/> JEBELAL19
Numero Blocchi.....(N/Mese)	4	<input type="checkbox"/> NOVARA	<input type="checkbox"/> SAMALKOT	<input type="checkbox"/> SERVOLA	<input type="checkbox"/> SOLVAY1
Costo Recoting.....(Lit/Mese)	0	<input type="checkbox"/> TEVEROLA1	<input type="checkbox"/> TEVEROLA2	<input type="checkbox"/> ZAHRANY	
Giorni Fermo Macchina.....(gg/Mese)	17	Stati Operativi Macchina			
Numero Ordini:	36087	<input type="checkbox"/> Fermo	<input type="checkbox"/> Fermo Minor	<input type="checkbox"/> Fermo Major	<input type="checkbox"/> Fermo Guasto
Simulazione al:	42 %	<input type="checkbox"/> Avvio	<input type="checkbox"/> Inizio Minor	<input type="checkbox"/> Inizio Major	<input type="checkbox"/> Inizio Riparazione
- Channels:** A small window on the right with a text snippet: "Il Form 'Magazzini' permette di avere una fotografia dei Magazzini in ogni istante di tempo, evidenziando per ogni Item la quantità presente, la Scorta Minima di Sicurezza e il Tipo di Item."



WOLVES

Warehouse Organization & Logistics Virtual Environment Simulation

WOLVES focuses on Inventory Management & Warehouse Control in an advanced Framework integrating ERP, AI, Forecasting and dynamic planning. WOLVES was successful applied to a wide spectrum of industrial cases: from SME involved in production to large mass transportation companies; the results obtained was usually very successful reducing the inventory even to 50% with service improvements

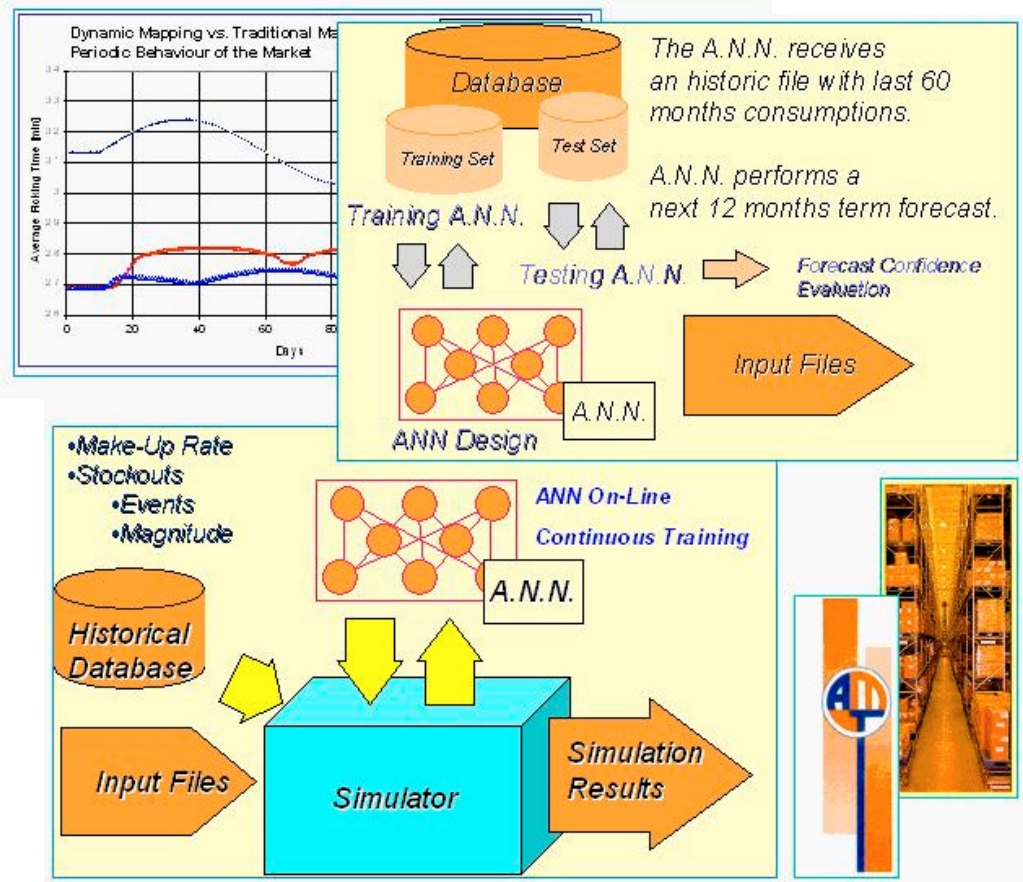



FUSE

Fuzzy Logic Schedule Analyzer

AnsaldoEnergia

FUSE is a package operating on PC and fully integrated in Office Suite for Supporting Planning and Management of Power Plant Service.

FUSE analyzes different scenarios providing quantitative measures of the critical issues including: contractual aspects, technical regulations, resource constraints, user needs, etc. FUSE properly reproduce the different parameters in order to support operative planning

The screenshot displays the FUSE software interface. At the top, there is a 3D model of a large industrial component, possibly a turbine or generator part, being lifted by a crane. Below this, the software window shows a control panel with various options and a data table.

Scenario	Results	Verbose	Clear List	EDH/DH	Historical Data	Source	C:\zoo2004\test\user		
FERRERA E. ENPOWER 1	0.69	0.69	1.00	0.75	1.00	0.75	1.00	0.00	1.00
FERRERA E. ENPOWER 2	0.69	0.69	1.00	0.00	1.00	0.00	1.00	0.00	1.00
RAVENNA ENPOWER 1	0.69	0.69	1.00	0.00	1.00	0.00	1.00	0.00	1.00
FERRERA E. ENPOWER 4	0.69	0.69	1.00	0.00	1.00	0.00	1.00	0.00	1.00
RAVENNA ENPOWER 3	0.69	0.69	1.00	0.00	1.00	0.00	1.00	0.00	1.00
FERRERA E. ENPOWER 1	0.71	0.71	1.00	0.00	1.00	0.00	1.00	0.00	1.00

Below the table, there is a summary window showing 'Scheduling Quality: 35/100' and buttons for 'Visualizza Scenario', 'Elabora', 'Risultati', and 'Fine'. The interface also includes a 'Performance' graph and various control buttons like 'Redraw', 'Exit', and 'About'.



LEM

Logistics Evaluation Model

LEM Project is a joint venture among Ford, Boston College, LSC & Genoa University for Developing a Web Based Support System for Supply Chain management.

Tests using LEM beta_modules have been carried out successfully on over 70 logistics centers.



LEM MAIN Menu

- Cars
- Suppliers
 - Products
 - Capacity
- Production
 - Sites
 - Lines
- Production Supplies

Production Lines Menu

Line ID	Line DAE1	Line DAE2	Line B&S	Line A1	Line A2
Car Type	Luxury	Compact	Luxury	Compact	Compact
Site	PS_01	PS_01	PS_02	PS_03	PS_04
Location	Pittsburgh	Pittsburgh	Clinton	Pocahontas	Florissant
Initial Max Capacity	600,000	400,000	500,000	750,000	750,000
Productivity Increase					
Theoretical Productivity	600,000	400,000	500,000	750,000	750,000
Current Production	400,000	250,000	200,000	650,000	400,000
Productivity	80%	63%	40%	87%	53%
Overall Efficiency	97%	97%	88%	94%	97%
MTBF	19.0	16.0	19.0	31.0	31.0
MTTR	1.4	1.2	1.4	2.2	2.0
Cost for Improving Productivity	9.78	8.8	9.78	8.8	8.7
Cost for Enabling new Cars same type	150,000	100,000	160,000	140,000	140,000
Car already Enabled	CA_01	CA_02	CA_03	CA_04	CA_05
	Yes	Impossible	Yes	Impossible	Impossible
	CA_06	CA_07	CA_08	CA_09	CA_10
	Impossible	Impossible	Impossible	Yes	Impossible
	CA_11	CA_12	CA_13	CA_14	CA_15
	Impossible	Impossible	Impossible	Impossible	Impossible

Production Supply Chain

Production Site: PS_01 Pittsburgh

Car Model: CA_02 Car Mago

QtyDate	Chassis	Tires
Supplier	SUP_18 Sp	SUP_14 To
Production Quantity	1,0	1,370
Warehousing		
Calculate	Distance	233
	Transport No.	12



BALI

Bay Advanced Logistics Integrator

BALI is a web solution for planning the access of trucks to docking bays in order to consider planning, use coefficients, workloads, management of new time slots and different kind of goods. By this approach it is possible to obtain significant benefits in term of reduction the waiting time of trucks and optimize the workload

- Truck Driver
- Transportation Company
- Supplier
- Wholesaler
- Manufacturer

BALI

Administrator

Planner

Warehouse

Manager





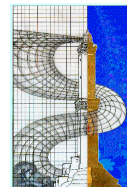

J20 Experience

E-Learning Concurrent/Cooperative Project Game

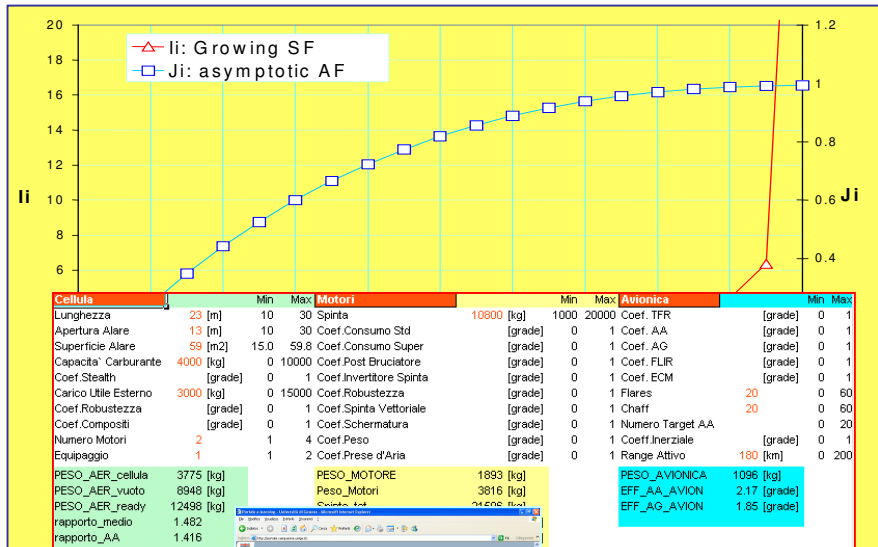

J20 allows to experience in a Web Based Environment a New Product Development by working in Cooperative Teams (Engine, Avionics Cell) representing different Joint Ventures competing for the Project a New Advanced Fighter.

The Exercise has been extensively tested in Distributed Environment for Professional and Academic Courses



NIG-29

Raggio d'Azione	229 km
Speed_Hi	2343 km/h
Speed_Low	1252 km/h
Alt	13 m
Altitude	6
Angle	3 [grade]
Angle	7 [grade]
M USD	7 M USD





WORM & WASP

Work Organization for Railways cargo Management
Wide Analysis of rail System and Performances



WORM is a simulator of freight rail operations for estimating service quality and costs.

WASP is a data mining system and smart performance analyzer directly integrated in railways information system.

WASP & WORM are integrated to operate as DSS for ASA Logistics Div. in Italian Railways

WORM

WASP Main

matricola	1	2	3
0183075610	1) CMVR 0 min 0 km h	2) SPVU 0 min 0 km h	matricola 0183120045
0183120045	1) EMVU 0 min 0 km h	2) NVVU 0 min 0 km h	3) NVVU 0 min 0 km h
0183120148	1) NVVU 0 min 0 km h	2) NVVU 0 min 0 km h	3) NVVU 0 min 0 km h
0183075610	1) NVVU 5030 min 0 km h	2) NVVU 5030 min 0 km h	matricola 0183120045
0183120045	1) EMVU 0 min 0 km h	2) NVVU 0 min 0 km h	3) NVVU 0 min 0 km h
0183120148	1) NVVU 0 min 0 km h	2) NVVU 0 min 0 km h	3) NVVU 0 min 0 km h
0183075610	1) ATVU 185 min 3 km h	2) ATVU 185 min 3 km h	matricola 0183120045
0183120045	1) EMVU 0 min 0 km h	2) NVVU 0 min 0 km h	3) NVVU 0 min 0 km h
0183120148	1) NVVU 0 min 0 km h	2) NVVU 0 min 0 km h	3) NVVU 0 min 0 km h
0183075610	1) VAVU 41 min 26 km h	2) VAVU 41 min 26 km h	matricola 0183120045
0183120045	1) VAVU 63 min 59 km h	2) VAVU 63 min 59 km h	3) VAVU 63 min 59 km h
0183120148	1) VAVU 60 min 129 km h	2) VAVU 100 min 125 km h	3) CAVU 110 min 417 km h



SOFRA & ATARDPL

Cleaning & Garbage Collection

The projects SOFRA focuses on Street cleaning in an urban context and use a combination of Genetic Algorithms and Simulation in order to optimize mission planning considering all the constraints; this approach guarantees improvements of 30% in term of quality of the service without additional investments just based on mission reorganization

The ATARDPL is based on SOFRA concept and it is devoted to Garbage Collection Planning (i.e. plastic, glass, paper) in Environmental Town Management and it guaranteed on real cases improvements in term of cost savings (10-20% reduction).

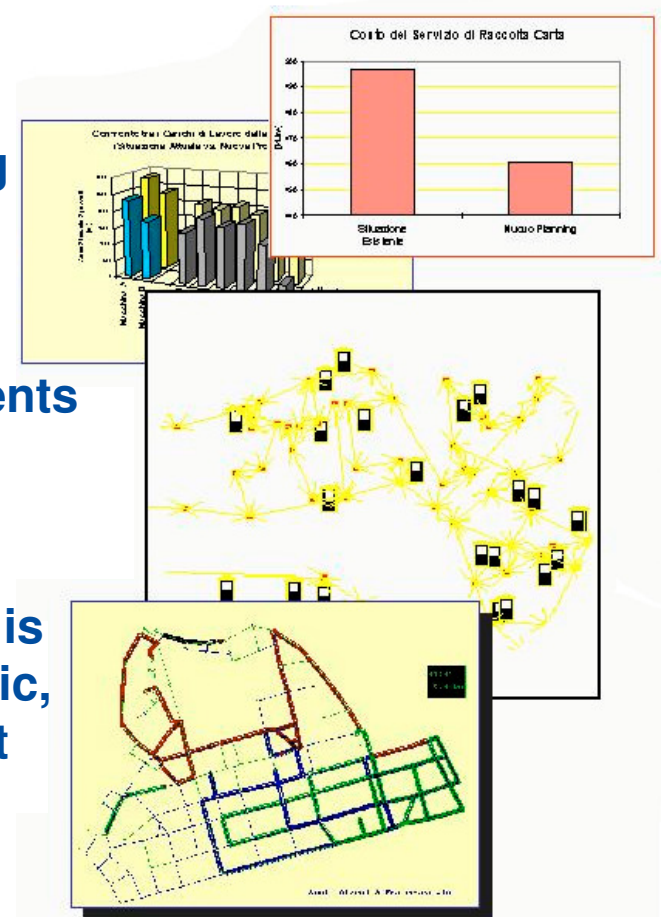



San Paolo 2000

San Paolo Hospital in Savona: Simulation for Architecture

San Paolo 2000 is the integration of simulation with architectural techniques for functional design and analysis of urban areas and buildings.

The system reproduce the Savona Downtown with the restoring project of this building using VRML 2.0 for exploitation of the results in the public community by WWW; it's possible to navigate in the scenario and to watch the interactions of simulated cars and people

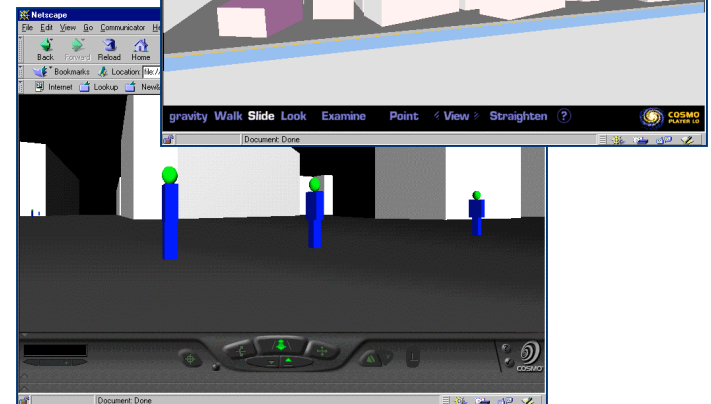
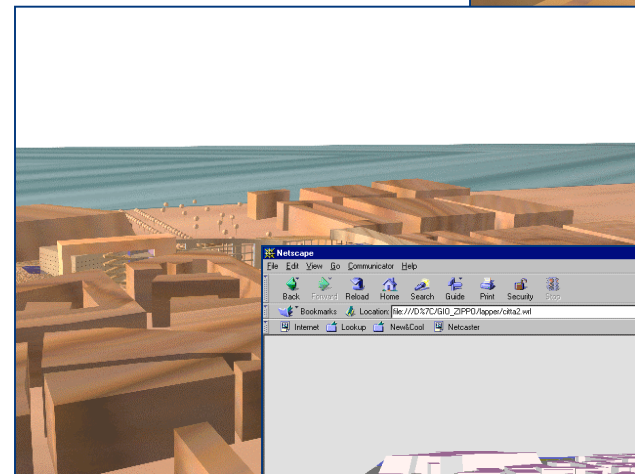



Alippo

Virtual Prototyping for Automotive Production & Design

Alippo Project is the development of a Model for integrating Design and Production Environment in Automotive Component Industry.

The system connects the Product Design provided by CAD systems (i.e. CATIA) with the Production Processes using Simulation.

Alippo simulates the production system considering the changes and valorizes the design changes in terms of Work in Process, Warehouse Saturation, Effective Productivity etc.

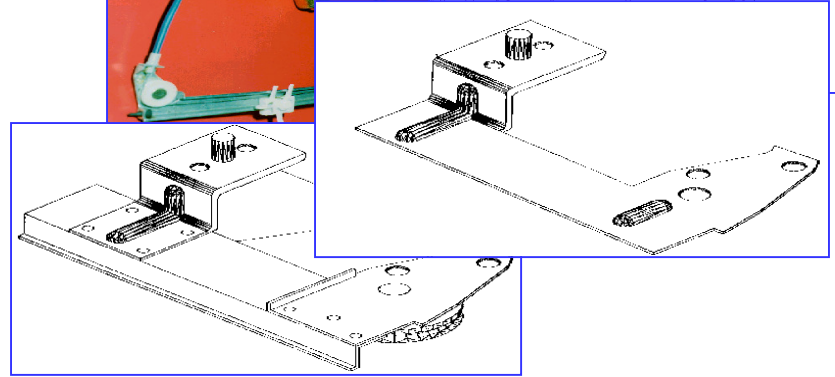
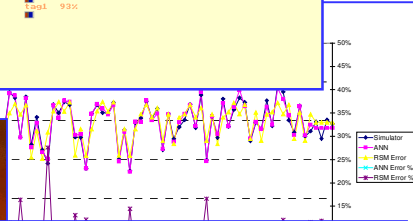
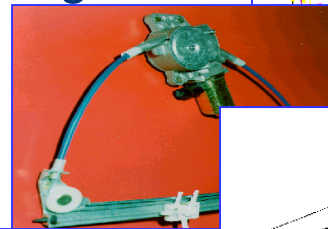
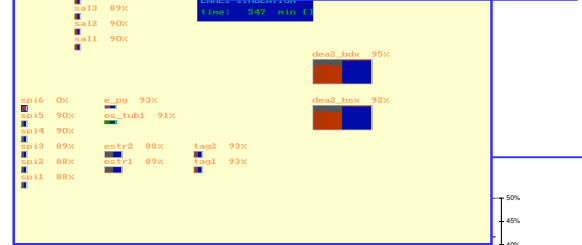
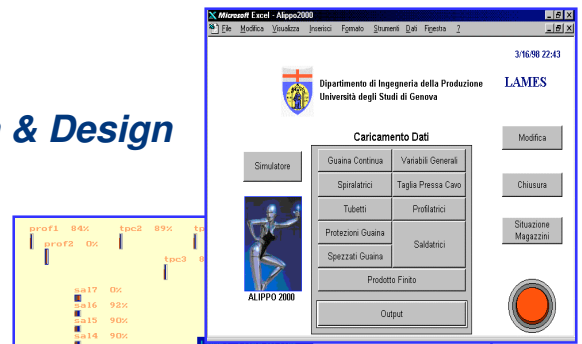



TRAMAS 4.0A

Transportation Management & Simulation for Transportation Managers

TRAMAS 4.0A is a tailored release devoted to organize Business Games for Education of Managers from Small Medium Size Transportation Enterprises. The Project was successfully applied in several courses sponsored by Italian Transportation Department.

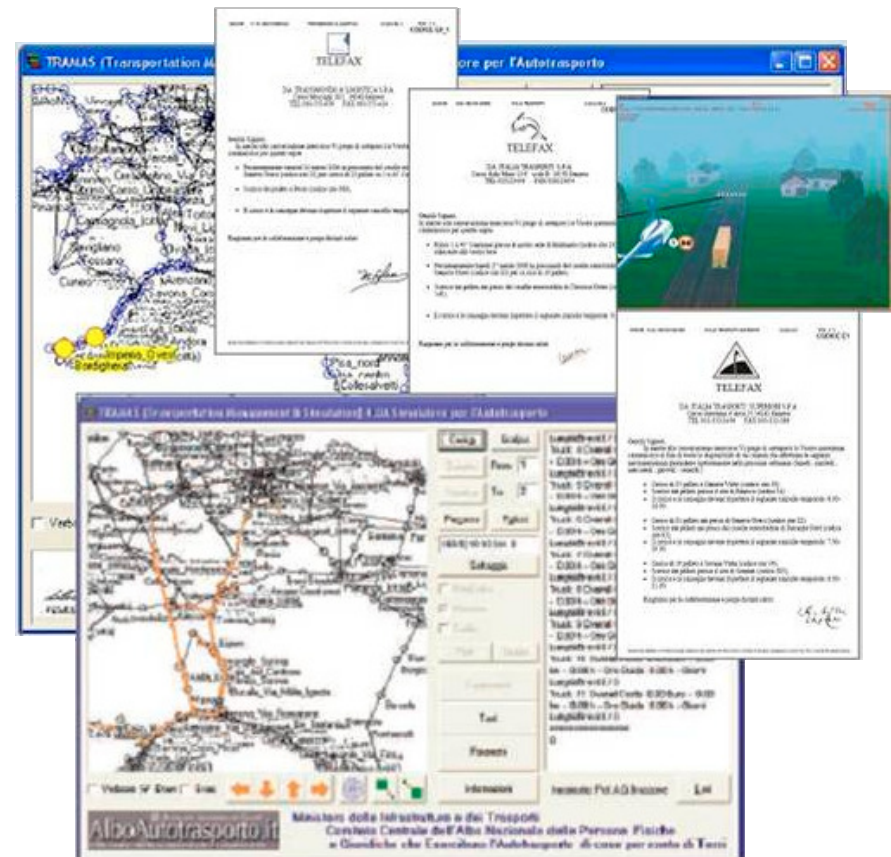



TRAMAS

Transportation Management & Simulation

TRAMAS is devoted to analyze complex scenarios involving transportation over a wide geographic area. The TRAMAS Simulator analyzes Costs, Times, Constraints and includes all the major factors such as:

- Traffic
- Weather
- Road Saturation
- Time Constraints
- Infrastructures
- Logistics Processes
- Cooperative Operations
- Shuttle Services
- Multipick and Multidrop

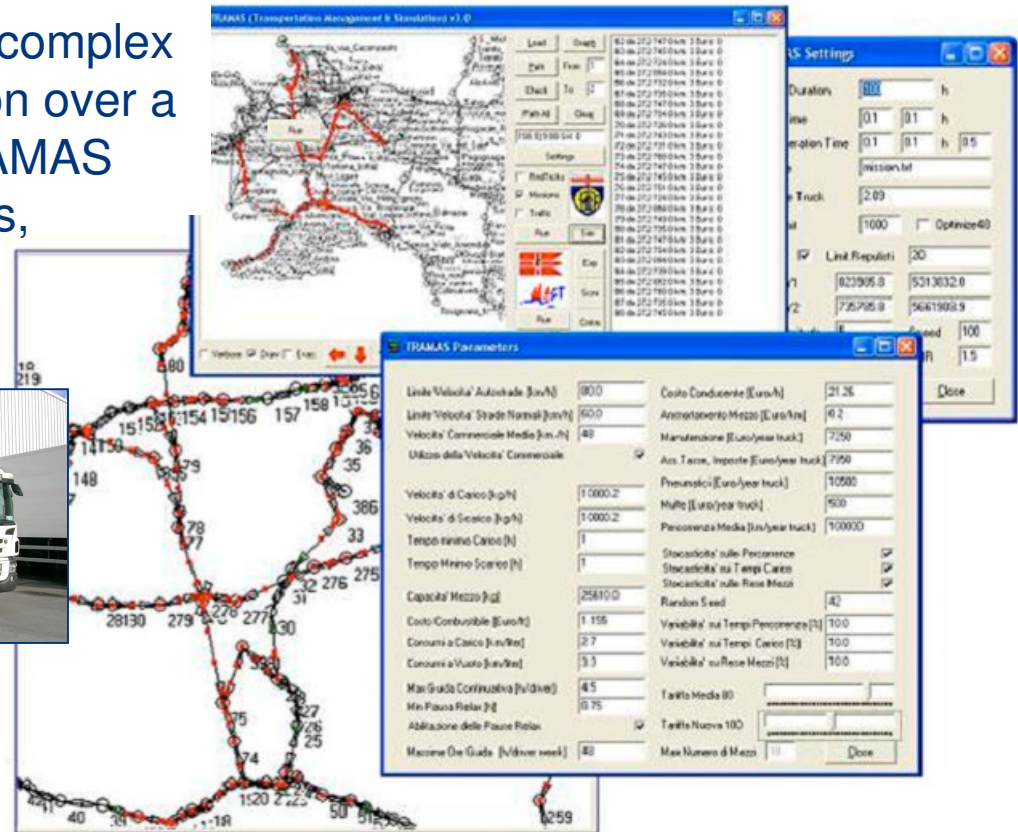



DISPOS

Disponibilità di Impianti di Scasellatura POStale



DISPOS is a suite devoted to certify availability and reliability in complex postal Production Lines characterized by multiple operative configuration.

DISPOS integrates historical data with *a priori* analysis based on simulation.

The systems include references to the international regulations (i.e. CQA UNI 9910, FEM 9.221, NASA TM4628A, DR01-3 DR01-27 NASA LeRC r4, MIL-STD-1388-2B, MIL-STD-49506)

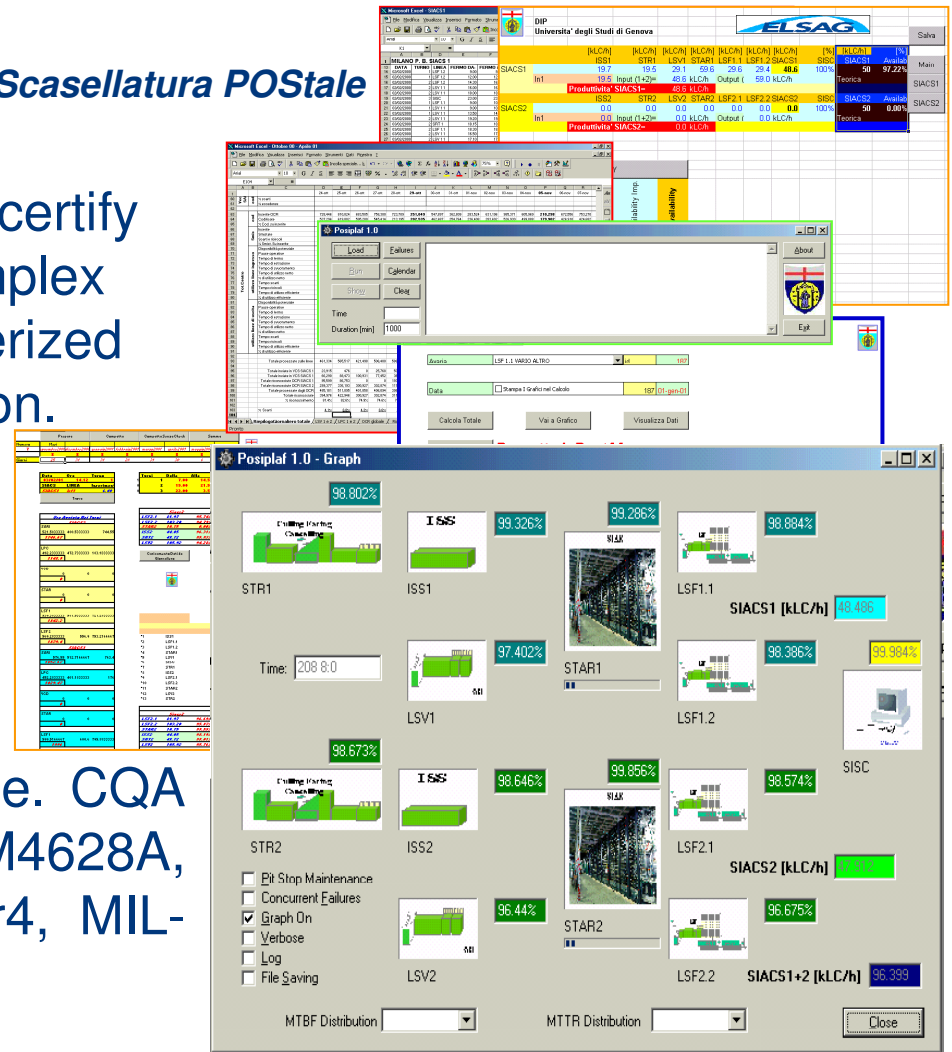



MACACO

Modelling Air Craft Analysis for Construction process and Organization

MACACO is a solution for improving production of executive planes in Aerospace Industry. The project involved data collection and analysis, modeling and simulation, experimental analysis as well as development of Intelligent systems based on AI for identify source of risks for plane due deadline.

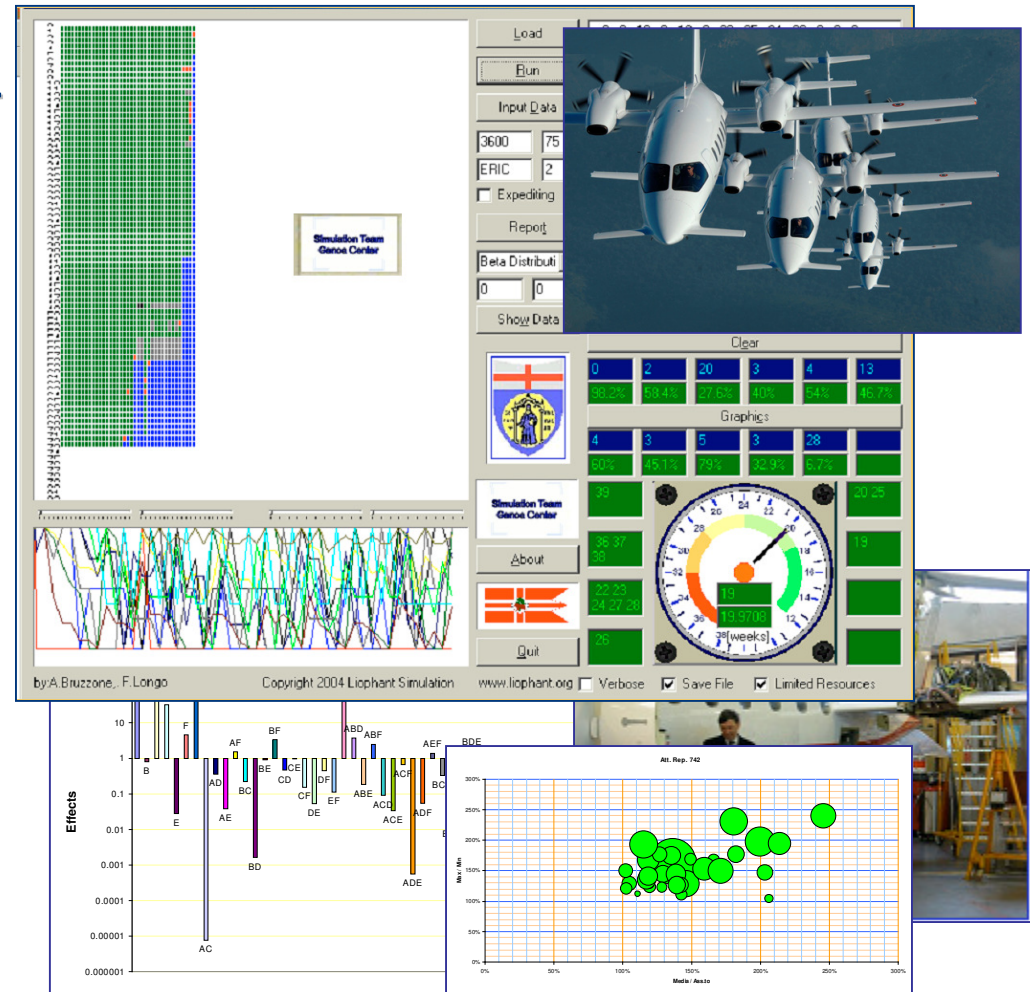



WILD

Web Integrated Logistics Designer

The WILD project involves the development of a Federation composed by Simulators, Scheduling Systems and ERP.

WILD Federation reproduces the supply chain and supports on-line distributed management and control among customers, main contractors, suppliers

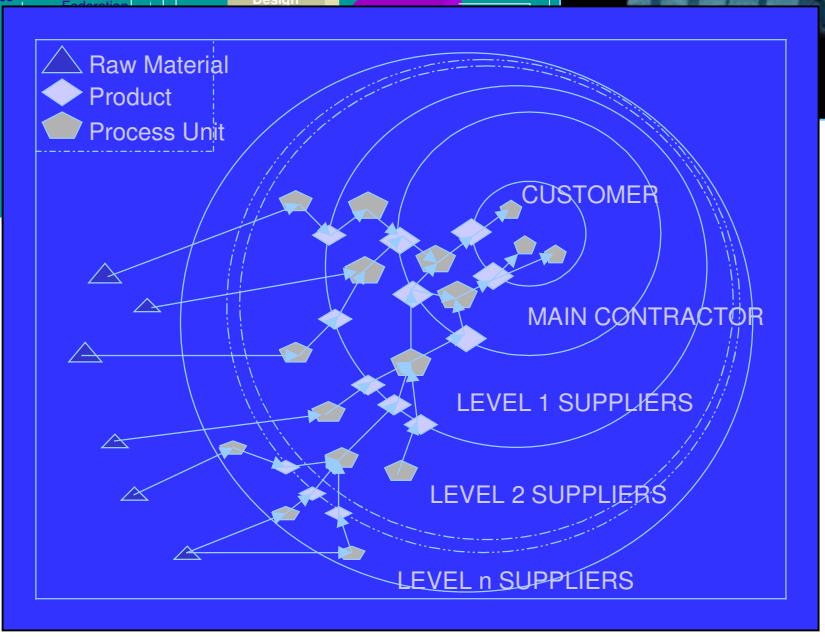
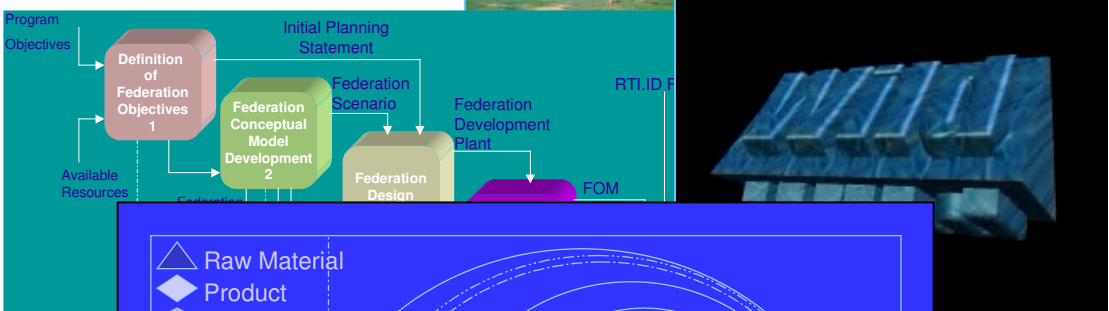



MARLON

MARitime LOGistic Network



MARLON is a model that allows the evaluation of costs related to different marine logistics scenarios. MARLON has innovative features like interoperability, Interactivity and Integration with GIS so companies have demonstrated interest about these; MARLON is a critical support for organizing distributed Meetings concerning tactical and strategic decisions on logistics and production (investments and budget) as well as Videoconferences to evaluate critical operations and scheduling decisions. MARLON is an integrated solution combining Simulation and Optimization, so MARLON is a DSS that improves planning and management of resources for liquid bulk transportation reducing the total cost for transportation and related risks. MARLON also allows to put in contact logistics with production and make their integration in the company's context easier. MARLON simulator has been tested and validated giving output compatibles with other models and with real industrial case.

Marlon Parameters

- Flows
- Paths
- Ships
- Save on File
- Verbose Reports
- Dynamic Update
- Random Seeds: -1
- Duration: 1
- Regular Fuel Cost [%]: 1
- Port Fuel Cost [%]: 1
- Increasing Tanks Capacity [%]: 1
- Increasing Piping Flow Capacity [%]: 1
- Production Increase [%]: 1

Marlon - Maritime Logistics Networks

34	Bitihessa2	36.7167	20.8500
35	Bitihessa3	35.9500	23.1167
36	Bitihessa4	37.6667	24.1933
37	Bitihessa5	38.2167	24.8333
38	Bitihessa6	39.2667	24.0167
39	Bitihessa7	40.4333	22.7500
40	path4sottosicilia	36.2500	16.8333
41	path4sardegnacorsicaest	41.2833	9.7666
42	manica	50.8833	1.6167
43	nordhamburg	54.7167	6.4833
44	imboccaregibilterraest	36.3500	-1.4000
45	daravennaamarghera	44.9333	12.6833

Flows

1	flow1	4	Priolo_C4	Ravenna_C4	2795.3462
2	flow2	4	Porto_Marghera_C4	Ravenna_C4	1867.7693
3	flow3	5	Porto_Marghera_Etilene	Omisali_Etilene	1487.9423
4	flow4	5	Priolo_Etilene	Vada_Etilene	1406.2693
5	flow5	3	Brindisi_Butadiene	Ravenna_Butadiene	1335.8269
6	flow6	1	Priolo_Propilene	Brindisi_Propilene	1159.8654
7	flow7	1	Porto_Torres_Propilene	Brindisi_Propilene	1010.2692

Ports: Sites: Ships: Demand: Flows: Missions: Reorganize: Quit

Copyright (c) 2004-2010 Simulation Team MISS DIPTM University of Genoa GIS On Dynamic GIS



LOGOS

Logistics Optimisation System



EniChem

The project integrates simulation, planning scheduling and optimization methods based on Artificial Intelligence Techniques.

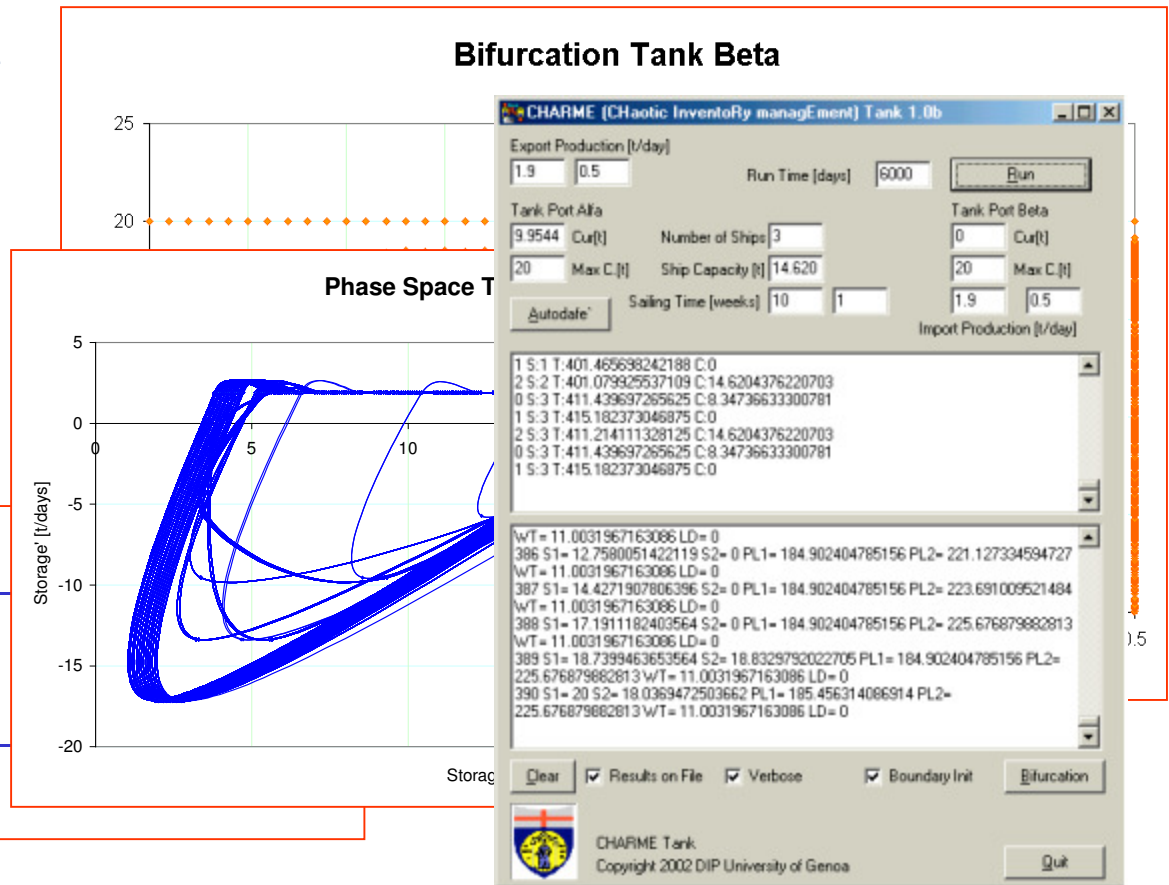
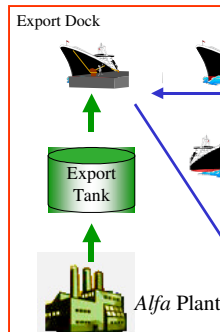



CHARME

CHAotic inventoRy ManagEment

CHARME is a set of modules developed by DIPTeM/Liophant as dynamic reference for VV&A (Verification, Validation and Accreditation) of LOGOS Decision Support System for Fleet Management (Planning, Scheduling & Simulation) in large chemical industries. CHARME uses chaos theory approach in application to real stochastic logistics networks.



CHARME (CHAotic inventoRy managEment) Tank 1.1b

Export Production [t/day]: 4 | 1 | Run Time [days]: 60 | **Run**

Tank Port Alfa: 30.188; Cur[t]: 40 | Loading Speed [t/day]: 24 | Number of Ships: 6 | Ship Capacity [t]: 14 | Sailing Time [days]: 10 | Tank Port Beta: 32.797; Cur[t]: 40 | Max C.[t]: 4 | 1 | Import Production [t/day]:

Autofade

```

0 S:1 T:60.5737838745117 C:0
1 S:1 T:66.513916015625 C:0
2 S:1 T:67.8479614257813 C:0
3 S:3 T:60.0703659057617 C:14
4 S:3 T:60.7590446472168 C:14
5 S:1 T:63.1290740966797 C:0
0 S:1 T:60.5737838745117 C:0
1 S:1 T:66.513916015625 C:0
59.9416847229004 S1= 30.1887321472168 S2= 32.7971496582031 PL1=
7.54530334472656 PL2= 15.9622440338135 WT= 0.109076499938965 LD=
1.60737609863281
59.942684173584 S1= 30.1887321472168 S2= 32.7971496582031 PL1=
7.54530334472656 PL2= 15.9622440338135 WT= 0.109076499938965 LD=
1.60737609863281
59.942684173584 S1= 30.1887321472168 S2= 32.7971496582031 PL1=
7.54530334472656 PL2= 15.9622440338135 WT= 0.109076499938965 LD=
1.60737609863281
  
```

CHARME (CHAotic inventoRy ManagEment) Sequencer 1.0b

Ports:

- 1 Genova: T:1 X:0 Y:0
- 2 Marsiglia: T:1 X:200 Y:0
- 3 Barcelona: T:1 X:400 Y:100
- 4 Pireo: T:1 X:1000 Y:800
- 5 Porto Saed: T:1 X:1500 Y:1500
- 6 Gibraltar: T:1 X:700 Y:800

Flows:

- F14 GLPW:900: from:1 to:4 == 2 Done
- F35 GLPW:900: from:3 to:5 == 3 Done
- F24 GLPW:500: from:2 to:4 == 5 Done
- F42 GLPW:500: from:4 to:2 == 3 Done
- F15 GLPW:900: from:1 to:5 == 4 Done
- F61 GLPW:500: from:6 to:1 == 5 Done

Tank Behaviour Graph:

Time [days] vs Inventory [t]

Liophant Simulation





MASC & DICO-SAP

Modeling & Analysis for Satisfaction of Customers
DIPTM-COOP SAP



MASC is a system for Statistical Analysis, Modeling & Simulation applied to big-distribution chains.

The Project is carried out in cooperation with the major Italian company in this area

The final target is to improve the customer satisfaction acting on policies, operating procedures, resources & equipment; the system is fully integrated with company ERP (SAP R/3) and benefits of similar experiences carried out other companies (i.e. Genoa Mass Transportation Company).

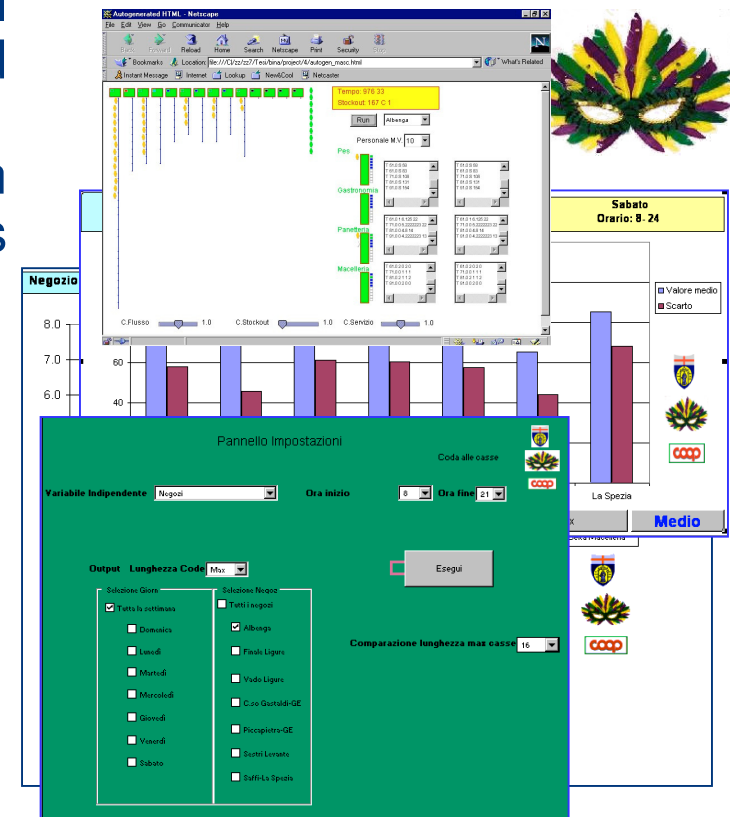



EFESTO

Elaborazione Flussi Economato Sistemi, Tecniche & Organizzazione

The EFESTO project is focusing on the creation of models for Business Process Re-Engineering integrating simulation techniques.

The system allows to integrate Office Suite, with simulation and to distributed the results directly in Intranet managing hierarchical process structure.

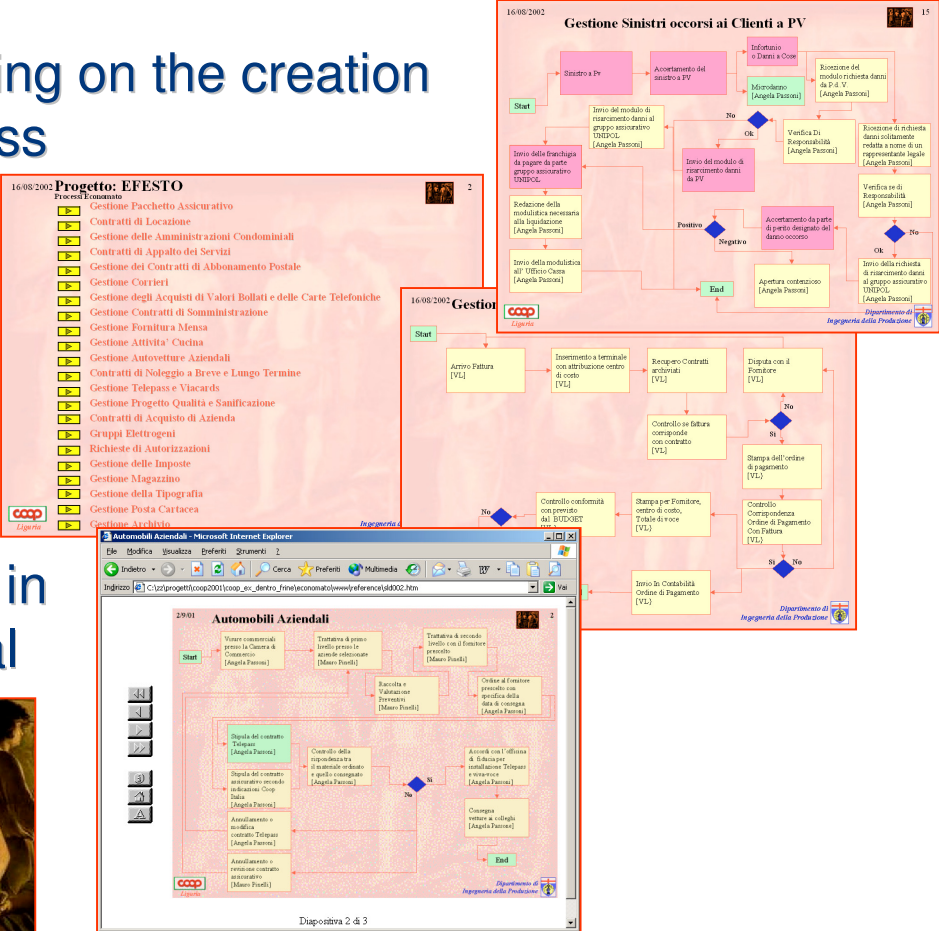



EPEO

Enhancement Process Efficiency & Organization

The EPEO project is devoted to analyze existing structures and to support process re-engineering and reorganization in Business Division of Big Companies geographically distributed. EPEO applies the state of art in Modelling and Simulation and other techniques for Process Identification, Mapping and Quantitative Analysis

	OBS	Model	Delta
CGAL	508.00 h/week	223.9995 h/week	284.00 h/week
RIORD	486.00 h/week	352.96226 h/week	133.04 h/week
SegComm_Lig	304.00 h/week	189.8 h/week	114.20
SegComm_Lom	190.00 h/week	162.75 h/week	27.25
SegComm_Pie	361.00 h/week	238 h/week	123.00

Department: CGAL

Unit: CGAL3

Scenario: Regime

Graph

Summa

People CGAL3

Notes: AP65 Creazione condizioni di acquisto / AP61 Inserimento analgrafica promozioni / AP120 Inserimenti condizioni di sconto per referenza / AP130 Variazioni condizioni di sconto per referenza / AP22 Inserimento articoli su GDB /

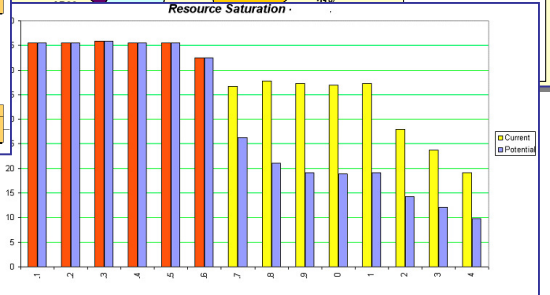
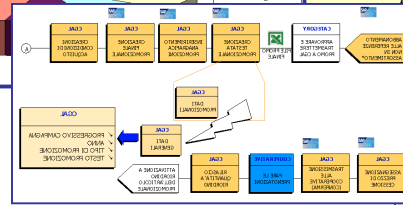
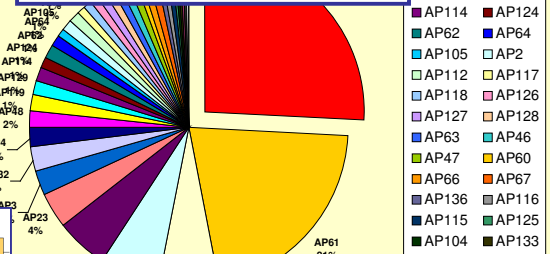
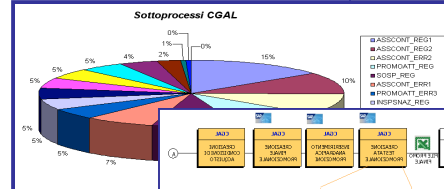
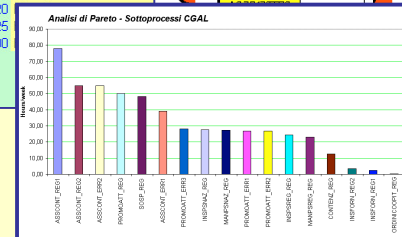
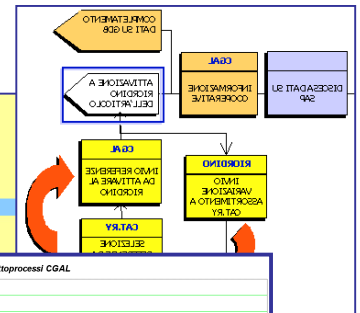



AVICUNICOLA

Project for Logistic Platform devoted to White Meat Fresh Products

The project is devoted to the architecture definition, system development and testing for a new logistics platform integrated in a large supermarket supply chain. The system was implemented in SAP R/3 Retail 4.6™



The screenshot displays the SAP R/3 interface for MRP planning. The main window is titled 'Elaborare lista pianificazione MRP deperibili'. It shows a list of materials with columns for 'C' (Material), 'C' (Article), 'Fornitore' (Supplier), 'C' (Order), 'ORDACQ' (Order Type), 'U.' (Unit), 'Diversa' (Different), 'Unità' (Units), 'U.' (Unit), and 'Definizione' (Definition). The list includes various meat products like 'POLLO BUSTO COOP GRILL' and 'POLLO PET COOP FETT'. Below the list, there are several status indicators (green, red, yellow) and a legend at the bottom right.





NOL

New Opportunities for Logistics



Consorzio Nord-Ovest

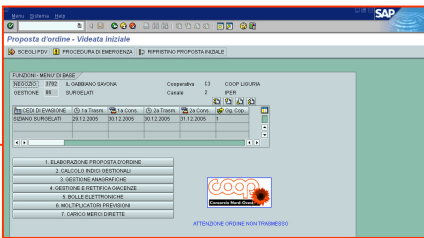

The project is focusing in logistics solution consulting and analysis for CCNO, a Consortium providing Logistics, Administration and IT services to Retail Networks in North Italy.

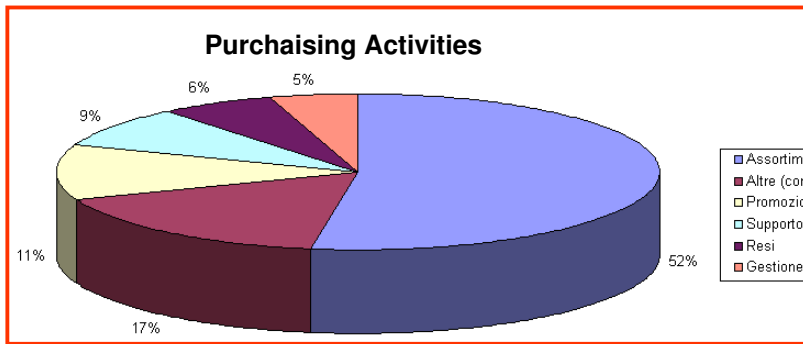
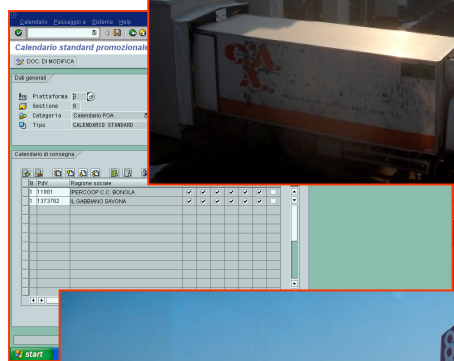
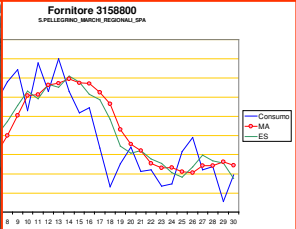



CAPE

Carni & Pesci

The project is focusing in redesign logistics solutions for distribution of fresh food with special attention to Meat and Fish. The project focused on logistics with special attention to platform, infrastructures, processes and distribution policies and procedures.

The screenshot displays the TRAMAS 4.0A simulation interface. At the top left, a map shows the region around Milan, Novara, and Pavia. To the right, a bar chart titled 'Meat Flows [kg/week]' shows weekly data with a significant peak in late 2004. Below the map is a grid of 12 process flow diagrams, each representing a different simulation scenario (e.g., Scenario 1: Meat 0, Scenario 2: Meat 10, etc.). At the bottom, a photograph shows several trucks parked in a yard in front of a large industrial building.



POA NG

Proposta d'Ordine Automatico New Generation

POA NG is a project for developing a new system for inventory management of shopping centers in large retail chains. RIO NG optimize the different inventory management models by using stochastic simulation approach and it is currently operative directly implemented in SAP R/3 by major Italian Retailers.





RIO

Renovating Intelligent Operations

RIO is an innovative solution develop in Web Framework for Operation Control in Wide Supermarket Networks RIO allows both to control store and department performances (sales, customers, goods, productivity, workload) as well as to predict their behavior for improving the performances





6EFFE

Flessibilità a Favore dei Figli e delle Famiglia, Formazione e Fidelizzazione

6EFFE project is a strategic project sponsored by COOP Liguria and National Departments for designing and experimenting new flexible work solution in supermarkets. DIPTTEM was in charge of model development and general architecture design.

MASC NG v2.34b

Entity Process: PdV: 62, Dpt: 3, Date: 10012005, Ref: 10012005

Test Time: 36, 42, 80, 425

Day 6 Hour: 20:45 People: 4
Day 6 Hour: 21:0 People: 4
Day 6 Hour: 21:15 People: 4
Day 6 Hour: 21:30 People: 2.5
Day 6 Hour: 21:45 People: 1
Day 6 Hour: 22:0 People: 0.5
Day 6 Hour: 22:15 People: 0
Day 6 Hour: 22:30 People: 0
Day 6 Hour: 22:45 People: 0
Day 6 Hour: 23:0 People: 0

Main window: OGGI 28/09/2004

Data	Valore	ORARIO DI LAVORO					
		LUNEDI			MARTEDI		
		Mattino	Pomeriggio	Tot	Mattino	Pomeriggio	Tot
31/01/2002	16.21380			0.00			0.00
30/01/2002	75.71480			0.00			0.00
29/01/2002	28.53738			0.00			0.00
28/01/2002	72.20318			0.00			0.00
27/01/2002	51.28300			0.00			0.00
26/01/2002	0.19653			0.00			0.00
25/01/2002	51.36738			0.00			0.00
24/01/2002	28.01448			0.00			0.00
23/01/2002	97.92352	1		0.00			0.00
22/01/2002	18.61088	2		0.00			0.00
21/01/2002	19.98752	3		0.00			0.00
20/01/2002	35.19922	4		0.00			0.00
19/01/2002	35.90408	5		0.00			0.00
18/01/2002	76.80632	6		0.00			0.00
17/01/2002	70.73168			0.00			0.00
16/01/2002	79.77288			0.00			0.00
15/01/2002	62.57592			0.00			0.00
14/01/2002	38.19788			0.00			0.00
13/01/2002	12.18990			0.00			0.00
12/01/2002	49.57652			0.00			0.00
11/01/2002	3.424138			0.00			0.00

Media Mobile: 15
pendenza: 30
arte T1 (c1): 1
arte T2 (c2): 1
prima: 7
lopo: 8
ne M Mob Pes: 3
orni Settimana: 1.9;2.8;0.75;1.6;0.5;1.4

Dati di Origine Grafico Tipico

GENERI VARI																	
	0	0,25	0,5	0,75	1	1,25	1,5	1,75	2	2,25	2,5	2,75	3	3,25	3,5	3,75	4
Lunedì	1	1	1	1	1	1	1	1	1	1	1	1	1	1	1	1	1
Martedì	2	2	2	2	2	2	2	2	2	2	2	2	2	2	2	2	2
Mercoledì	3	3	3	3	3	3	3	3	3	3	3	3	3	3	3	3	3
Giovedì	4	4	4	4	4	4	4	4	4	4	4	4	4	4	4	4	4
Venerdì	5	5	5	5	5	5	5	5	5	5	5	5	5	5	5	5	5
Sabato	6	6	6	6	6	6	6	6	6	6	6	6	6	6	6	6	6
Domenica	7	7	7	7	7	7	7	7	7	7	7	7	7	7	7	7	7

SALUMI E LATTICINI																	
	0	0,25	0,5	0,75	1	1,25	1,5	1,75	2	2,25	2,5	2,75	3	3,25	3,5	3,75	4
Lunedì	0	0,5	0,75	1	1,25	1,5	1,75	2	2,25	2,5	2,75	3	3,25	3,5	3,75	4	4,25
Martedì	0	0	0	0	0	0	0	0	0	0	0	0	0	0	0	0	0





SPIRALS

Space Interoperable Refilling and Advanced Logistics Simulator

Location: **MOON**

- Latitude: 26 08' 9.94" N
- Longitude: 3 34' 40.34" E
- Elevation: -1828.8 m

Simulation Team



SPIRALS Project was developed by students of Genoa and Bordeaux Universities, in Internship in MAST and members of Liophant for Smackdown: this initiative is led by NASA, sponsored by several companies and devoted to advance HLA culture by creating a distributed HLA Federation of a Moon Base. SPIRALS federate is in charge of the inventory management, the operations & logistics in the Moon Base.

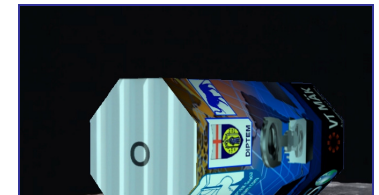

	Base: EA1 Oxygen: 100000 Water: 100000 Battery: 10000 Fuel: 10000		Base: MNBS1 Oxygen: 28 Water: 10 Battery: 8 Fuel: 14
	Addo (E) Addo (M) Addw (E) Addw (M) Addb (E) Addb (M) Addf (E) Addf (M)		Vehicles: Shuttle jLabel29 Oxygen: 30 Water: 30 Battery: 20 Fuel: 10

ChangeStatus [Icons] [Icons] [Icons] [Icons] [Icons]



DIPTM
Università di Genova



IPHITOS

Interoperable Simulation of a Protection solution based on light Interceptor Tackler operating in Outer Space

Location: **MOON**

- Latitude: 26 08' 9.94" N
- Longitude: 3 34' 40.34" E
- Elevation: -1828.8 m

Simulation Team



IPHITOS Project is developed by a team of students from different Universities (Genoa, La Sapienza Rome, Pisa), members of Liophant and students in internship in MBDA and support from Telespazio. This project is devoted to create a federate for Smackdown the initiative, led by NASA & sponsored by several companies, devoted to diffuse and advance the HLA culture by creating a distributed HLA Federation of a Moon Base.

IPHITOS federate is in charge of simulating small asteroids as threats for the Moon Base as well as a Safeguard Solution based on Interceptors, Sensors and Launchers

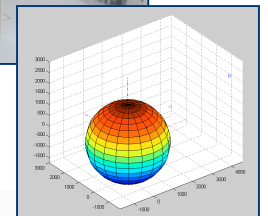
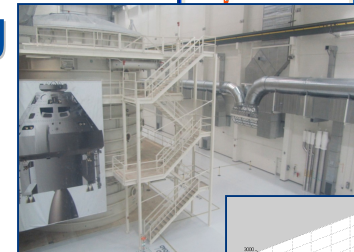
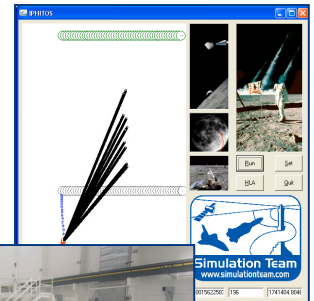



IPHITOS Space Guard

Interoperable Simulation of a Protection solution based on light Interceptor Tackler operating in Outer Space



IPHITOS Space Guard Project is developed by a team of young researchers from Genoa University in Internship in different organizations as new solution for Space Protection against asteroid of IPHITOS. This project is devoted to create a federate for Smackdown 2013 the initiative, led by NASA & sponsored by several companies, devoted to diffuse HLA Evolved culture by creating a distributed HLA Federation of a Moon Base. IPHITOS federate simulates debris & small asteroids as threats for the Moon Base as well as a Safeguard Solution based on Interceptors, Sensors and Launchers





BACCUS

Behavioral Advanced Characters & Complex Systems Unified Simulator



The BACCUS simulator is intended to be used to study the Obesity Epidemics considering both physiological and social aspects; the model reproduces the population dynamics, estimating correlation among different factors:

- BMI
- Sport Profile
- Stroke
- Alcohol Profile
- Infarct
- Atrial Fibrillation
- Diabetes
- Hypertension
- Cancer
- Hyperlipidemia

BACCUS simulates social networks such as Family and Friends to assess the population evolution and the mutual interaction with diffusion of pathologies

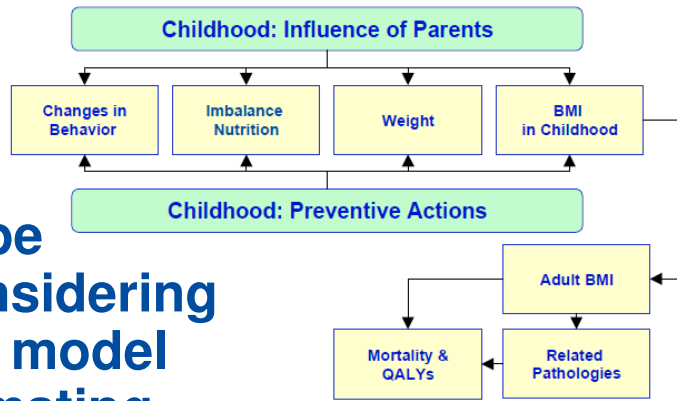

Basic Model of Obesity in Childhood



Beth Israel Deaconess Medical Center

A TEACHING HOSPITAL OF HARVARD MEDICAL SCHOOL

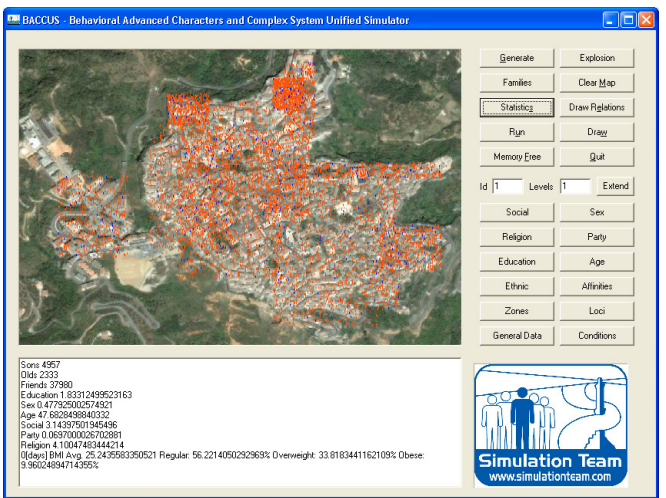



HOSSIAN

Hospital Simulation Analyzer

HOSSIAN is a tool developed to support resource planning in Hospital by integrating simulation and AI (Artificial Intelligence). The system has been successfully applied to the personnel and equipment scheduling in a Surgery Division composed by 6 operative rooms.

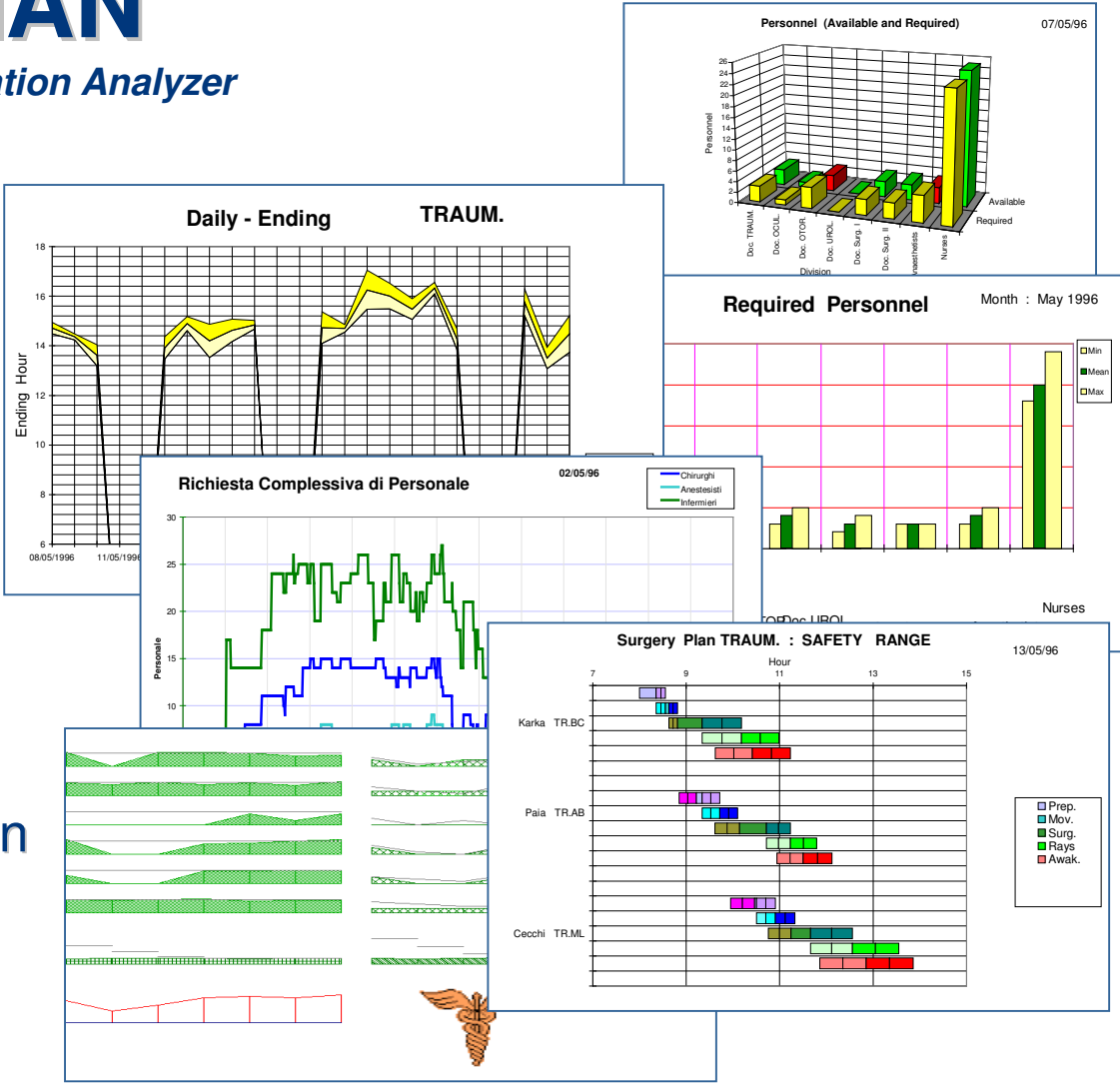



TEZNAME

Tactics Evaluation & optimiZation for Analysis in Medical Environment

TEZNAME is a tool for analyzing Hospital Departments Management considering the detail of each resource, individual and/or procedure.

The system has been successfully applied to Laboratory Re-engineering to compare different investments and policy/organization alternatives.

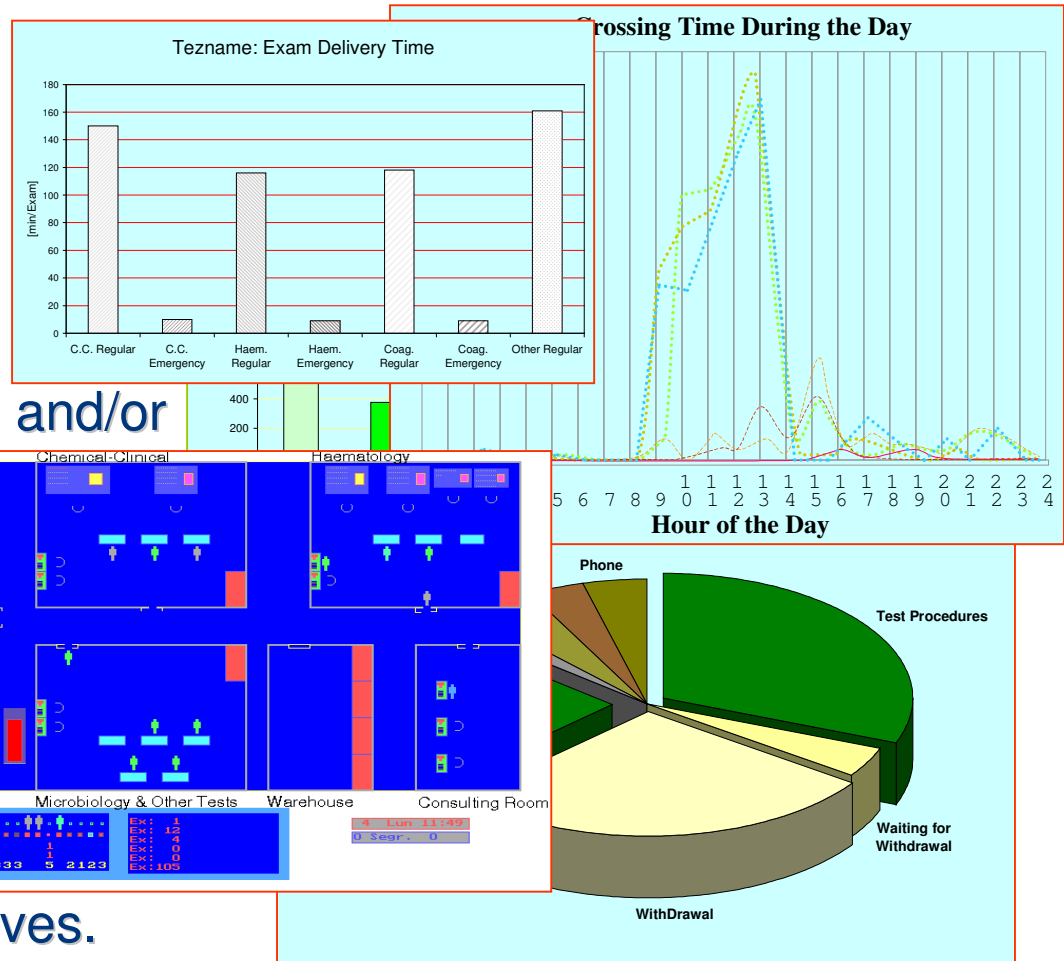



LOGIS

Long-distance tutorial network in Logistics Information Systems

LOGIS is a *Leonardo* project sponsored by European Community in order to develop Long Distance Tutorial Network in "Logistics Information System", Based on WEB Technologies. Besides the training, an interesting exploitation of the results of the research is related to the transfer of these techniques to Small - Medium size Enterprises.

Simulation Team

 Sponsored by
European
Community

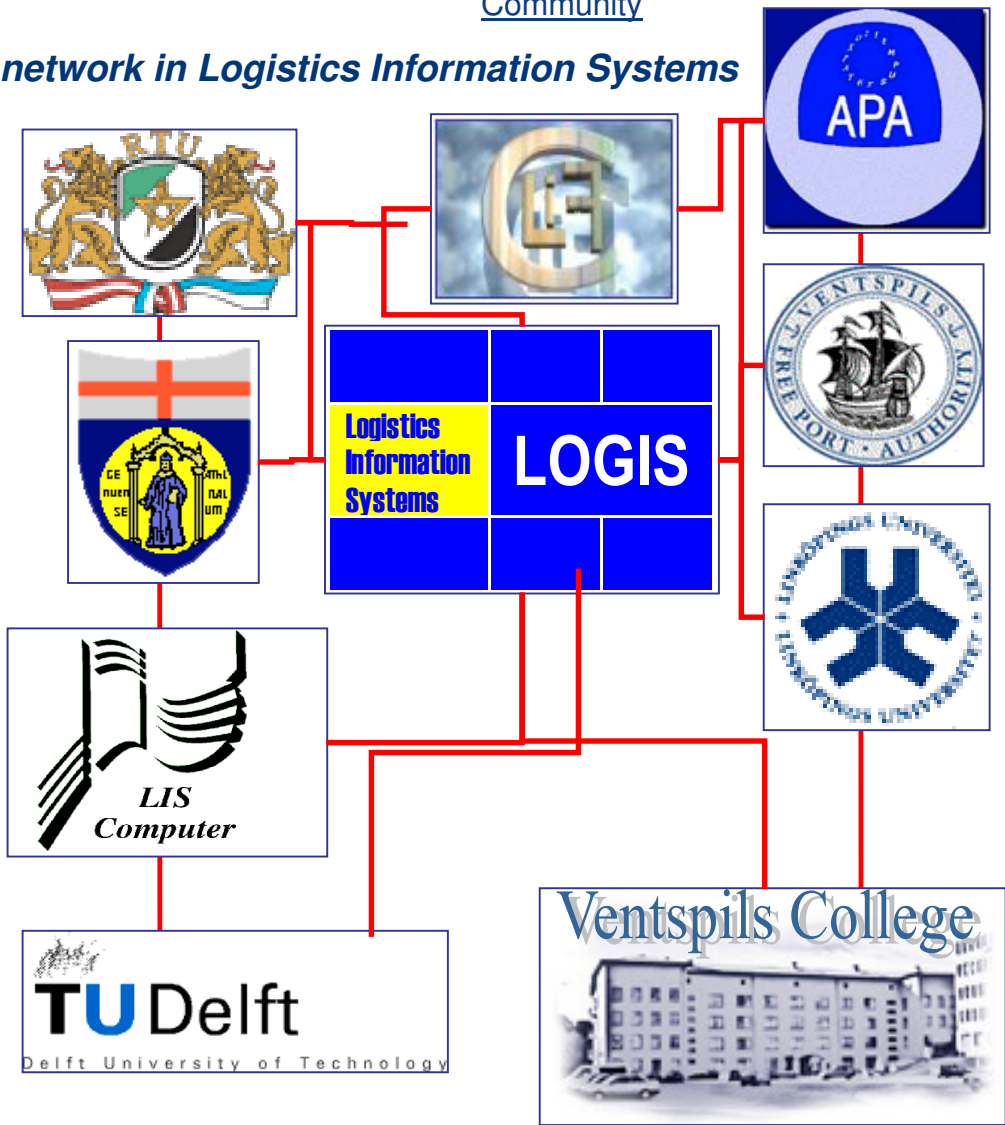



IEPAL

Intensive Educational Program in Advanced Logistics



IEPAL is a Co-funded project sponsored by European Community and US Department of Education, to live an academic & industrial training, to compare European and US way of living and working. A goal of this project will be the integration & exchange of different culture, the application of Web instrument and mobility to learn to cooperate. It is a Great Opportunity for engineering students and their curriculum to experiment in the new millennium Transatlantic Experiences in Enterprises and Universities working on Projects in **World-Wide Distributed Teams** focusing on the **Advances in Modeling & Simulation for Logistics and Supply Chain Management**

Simulation Team



Sponsored by:



FIPSE, US Department of Education

European Community, DGEAC



University of Central Florida



Boston College



LSIS - Marseille University



Magdeburg University



Consorzio di Formazione Logistica Intermodale



National Center for Simulation





LSCM

Logistics and Supply Chain Management International Master

LSCM Project is devoted to develop a Master Program for New Managers operating in Logistics and Supply Chain Management using innovative solutions such as M&S. LSCM involves an International Network with several Universities cooperating for creating this new Program.

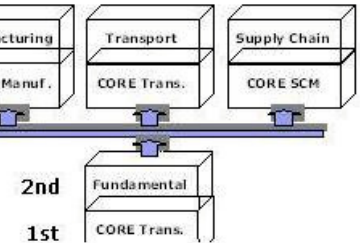
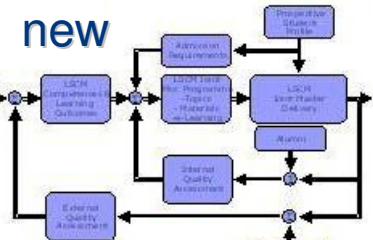
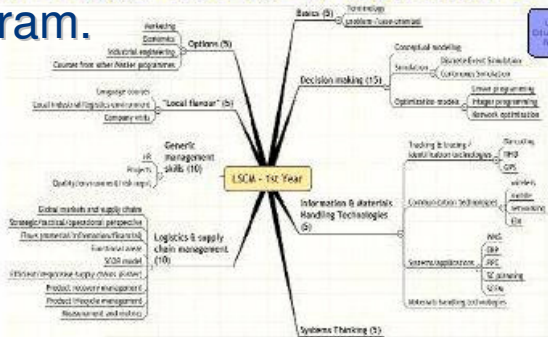

LSCM

134522-LLP-1-2007-1-ES-ERASMUS-ECDSP



MIPET Master Program

Master in Industrial Plant Engineering & Technologies
www.itim.unige.it/mipet



The Master in Industrial Plants is a Master degree program organized in Genoa University focusing on preparing new generations of top quality technical experts for process engineering and power equipment supplier as well as construction contractor. Its main aim it is to satisfy the expectation from Leading Industries in term of high technical skills and excellence capabilities in Industrial Plants and Engineering. The Master Program is directed by Faculty of Engineering in strong cooperation with leader industries and major companies operating in these industrial sectors, this aspect guarantees the relevance and effectiveness of the initiative. In fact this project it is part of a large initiative devoted to develop excellence in Industrial Plant Engineering through the synergy between the expertise of Genoa University Engineering Faculty and Top Level Companies with long traditions that are leading this Area Nationally and Internationally in term of turnovers, size, processes and products complexity as well as know how and technical skills.

PerForm Facoltà di Ingegneria Università degli Studi di Genova

Master in Industrial Plant Engineering and Technologies

SPONSORS AND SUPPORTERS

SPONSOR COMPANIES EDITION 2010

Prof. Agostino Bruzzone www.master-impianti.unige.it



PREMITELE Program

Preparation for Management within Innovative Transportation services and Evolving Logistics



PREMITELE Program (Preparation Business Management, Transportation and Logistics) was established to provide Methodologies and Tools for Transportation Services and Logistics with special attention on the following issues:

- *Assessment and Forecasting of logistics demand while facing emerging behaviors and new trends*
- *Definition of Evaluation criteria and solution for Supply Chain Management (SCM)*
- *Planning and Management of transport and logistics services*
- *Technology Transfer and Skill Acquisition on logistics considering operations, economy, legal aspects, engineering*
- *Identification of customer needs*
- *Use of Models and Tools for operative, economic & financial analysis and evaluation of investments and management solution for transport infrastructures and logistics*
- *Marketing planning for new transportation services and logistics*
- *Development of systems of management and control for Logistics and SCM*
- *Support and Guide the public administrators and operators in decision making and in the definition and implementation of realistic and effective policies in Transportation*

The aim of the course and then PREMITELE the preparation of a new generation of experts that who could be valuable in business within the area of Logistics and Transportation Services, becoming the new leaders in this area to support developments and strategic decisions and their implementation. People involved in the program should have skills in the fundamentals of engineering, economics, and regulatory and procedural issues related to transport and logistics characteristic within their university education; the attendees are students of Engineering, Economics or Law Faculties with Genoa, Rome, Bologna, Trieste, Salerno Universities. The PREMITELE is founded by the Italian National Department of Transportation.





DIMS PhD Program

*phD program in Innovative Mathematical engineering,
modeling & Simulation*



DIMS is a PhD program in Mathematical Engineering and Simulation sponsored largely by Simulation Team and Specific R&D Projects such as PIOVRA and CAPRICORN.

DIMS PhD program was activated by DIPTM (Production Engineering & Mathematical Modelling Dept.) and DIBE (BioEngineering Dept.) during fall 2005; today DIMS involves about 20 Courses in M&S for PhD Students and over 20 PhD Students are enrolled in this program.

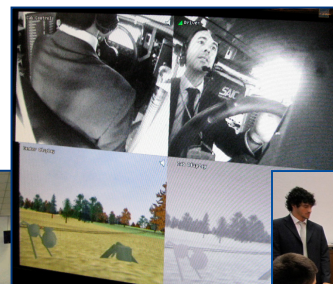

Simulation Team



Conclusions

The Simulation Team is acting at international level as a reference point between users and providers in simulation area.

The integration of experts, technicians is providing very good results on real case studies and complex projects.

An active area of development is related to distributed simulation and web-based modeling for extending the impact and exploitation of these proposed systems.

Every year Simulation Team - MITIM DIME and Liophant organize major Conferences and International Workshops focusing on application of Modelling & Simulation.

For instance the I3M2012 was in Wien, SummerSim2011 in Genoa, WAMS2012 in Rome; in 2013 I3M it was in Athens, WAMS in Buenos Aires and Summersim in Ottawa.

There is a constant interest in fostering joint cooperation and exchanges with international Excellence Centers working on simulation.

In 2014 Prof. Bruzzone serves as General Chair of WAMS in Istanbul as well as of I3M in Rome: this last conference

represent one of the major scientific event worldwide in simulation: i.e. the I3M2011 organized in Rome,

joint to CAX Forum, probably was the largest scientific event

in M&S worldwide, involving over 500 speakers from 52 countries and over 30 live

demonstrations (including Distributed simulation connecting NASA, MIT and Genoa University)





Potential Cooperations



Simulation Team

& NATO CAX Forum in Rome

Simulation Team provides R&D/Scientific Opportunities such as:

- Conferences and Track Organization in event where the Simulation is Strongly Involved (i.e. SummerSim, I3M, WAMS, AMS, ect)
- Exchanges for Senior and Young Scientists
- Opportunity for Scientific Cooperations devoted to promote new developments in M&S
- Developing new Standards and Procedures in M&S
- Promoting M&S in Service of the Society
- Development of Networks of Excellence in M&S

Simulation Team is looking for Opportunities including:

- Activation of Innovative Simulation Projects
- Combining Simulation Team Solutions with Partner's Models as Options to be proposed to Sponsors during the Proposal Phase
- Include in Simulation Team Solutions Add-In from Partners as Option for Sponsors during the Proposal Phase
- Supporting Partners in future Proposal acting directly or as subcontractor and viceversa
- Receiving Support by Partner in future Proposal acting directly or as subcontractor



IMAACA



Bond graph

Summersim



References

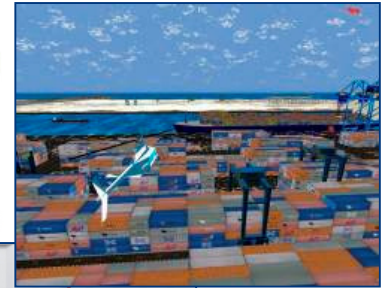
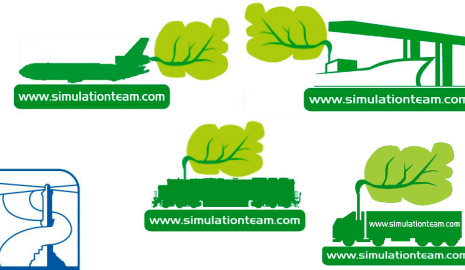

DIME



MITIM
DIME Genoa University
via Opera Pia 15
16145 Genova, Italy
www.itim.unige.it
Agostino G. BRUZZONE
agostino@itim.unige.it

